

Additive Manufacturing of Metallic Materials: an Introduction

A. Mertens, Université de Liège
anne.mertens@ulg.ac.be
<http://orbi.ulg.ac.be/>

Outline

- General introduction
 - What is Additive Manufacturing?
 - Advantages and drawbacks
 - Main A.M. processes for metals
- Current issues in the laser additive manufacturing of Ti alloy Ti6Al4V
- Laser additive manufacturing of metal matrix composites (MMCs)

General Introduction

What is Additive Manufacturing?

- Parts are built by depositing material layer-by-layer
- One layer = one section of the original CAD file

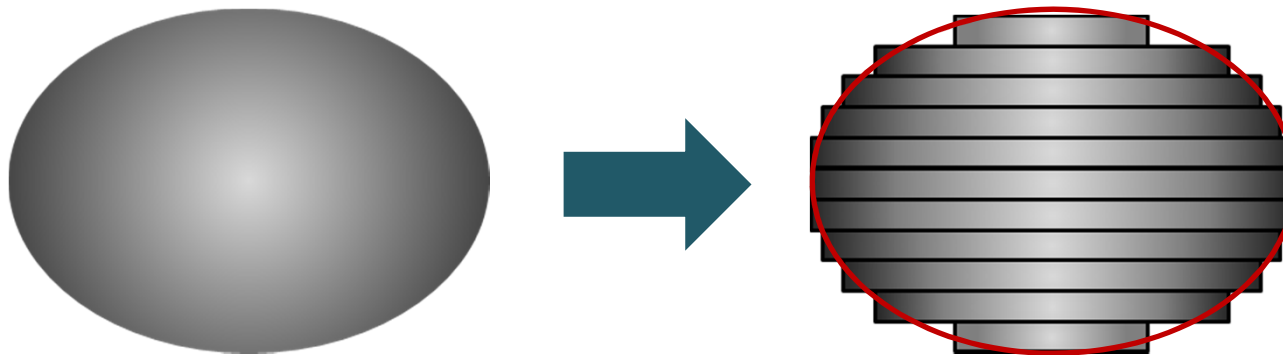

How does A.M. compare with conventional processes? → **machining or casting**

Machining

- High precision
- Complex process, long time
- Tool (wear)
- A lot of material is wasted
- One single material/part
- Geometrical limitation

Casting

- High production rate
- 1 mold = 1 part
- Complex process (shrinkage, porosities...)
- Trials and errors to find the right set of parameters and mold are costly and time-consuming
- One single material/part
- Geometrical limitation

A.M. is suitable for complex shapes

The design of a part is not limited by machining's constraints anymore.
The design may be modified e.g. to make the part (much!) lighter.

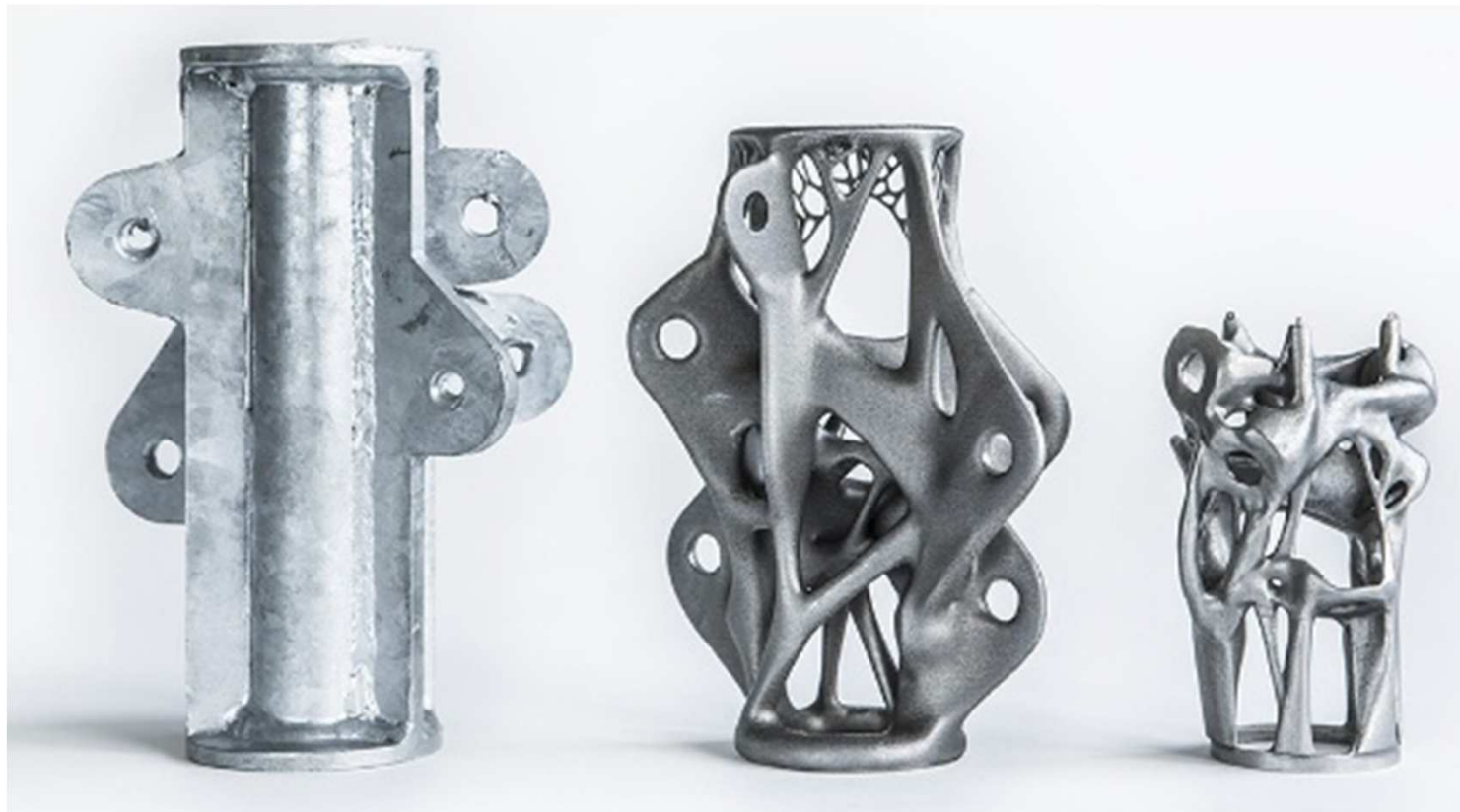

[Sirris]

A.M. advantages and drawbacks

+

- Little to no waste of material
- No tool, no mold
- Complex shapes are possible
- **Complexity does not increase the cost**
- **Weight reduction is quite easy**
- Short development time
- Added functionalities
- **Some techniques allow for processing "multimaterial" (Composites, Functionally Graded Materials...)**

-

- Production itself may be quite slow (1 "job" = up to 1 day)
- Accuracy/surface finish are lower than for machining
- Post-machining is often necessary
- Supports may be needed during fabrication (**to be removed!**)
- Residual (un-melted) powder must also be removed
- **Anisotropy**
- **Process control and reliability?**

A.M. processes for metals (1)

"Binder Jetting"

- Temporary consolidation is ensured by a binder.
- Post-processing (sintering or infiltration) is needed to obtain fully dense and solid part.

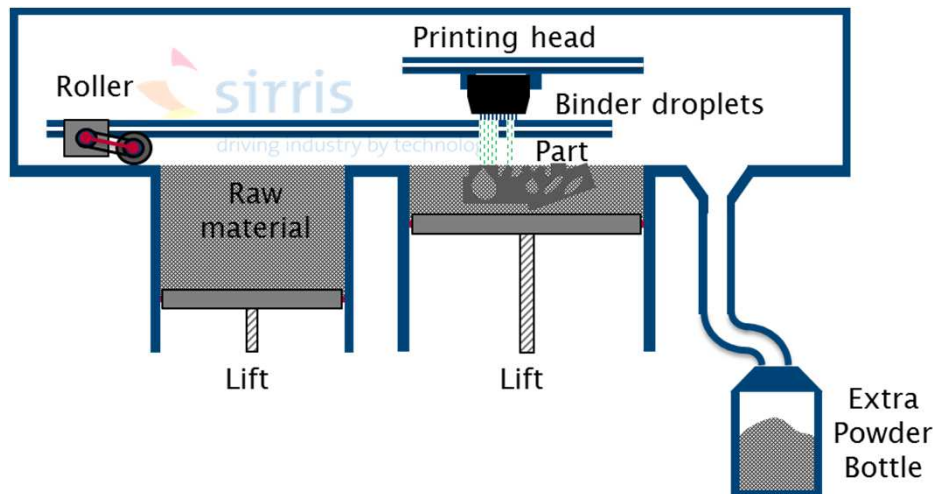

"Selective Laser Sintering"

- Consolidation is obtained through sintering and/or partial melting.
- Some residual porosity

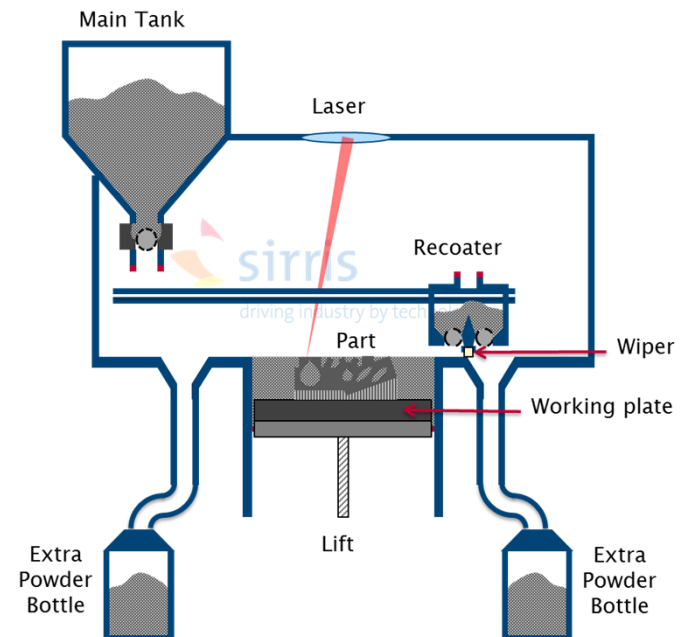

A.M. processes for metals (2):

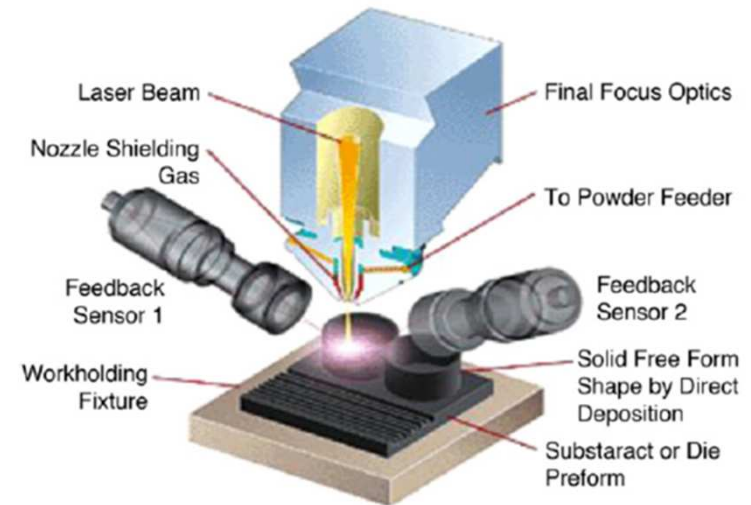
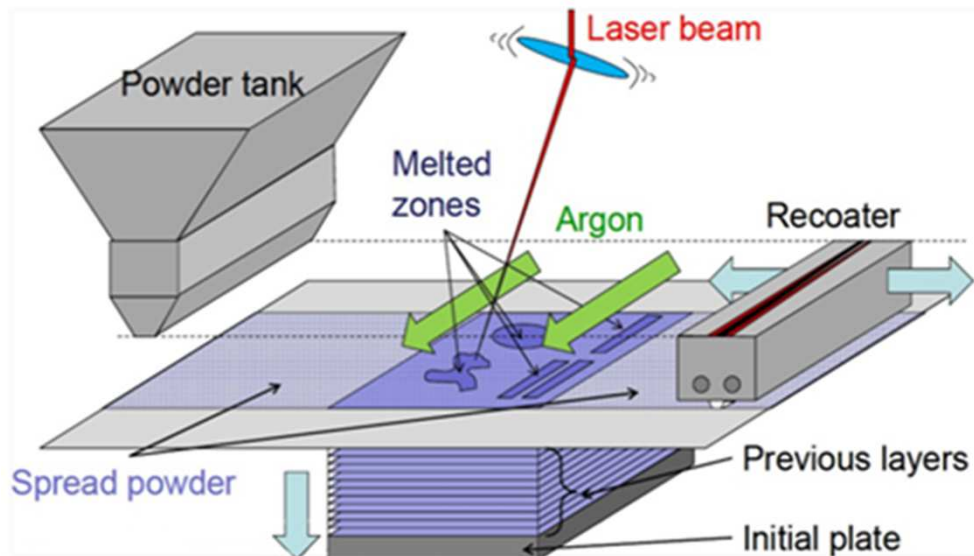
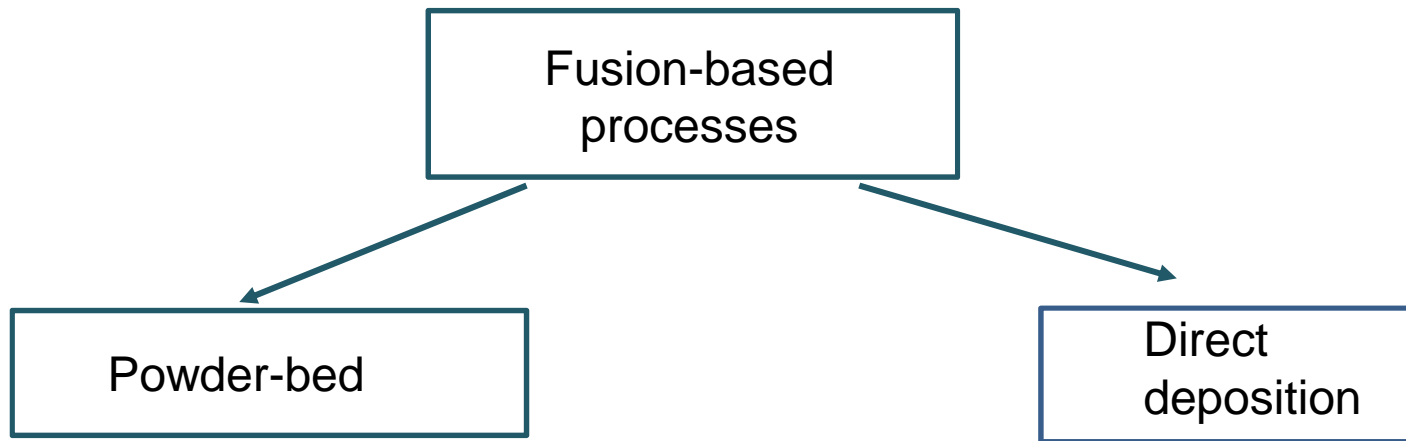

[Bhattacharya et al., 2011]

A.M. processes for metals (3):

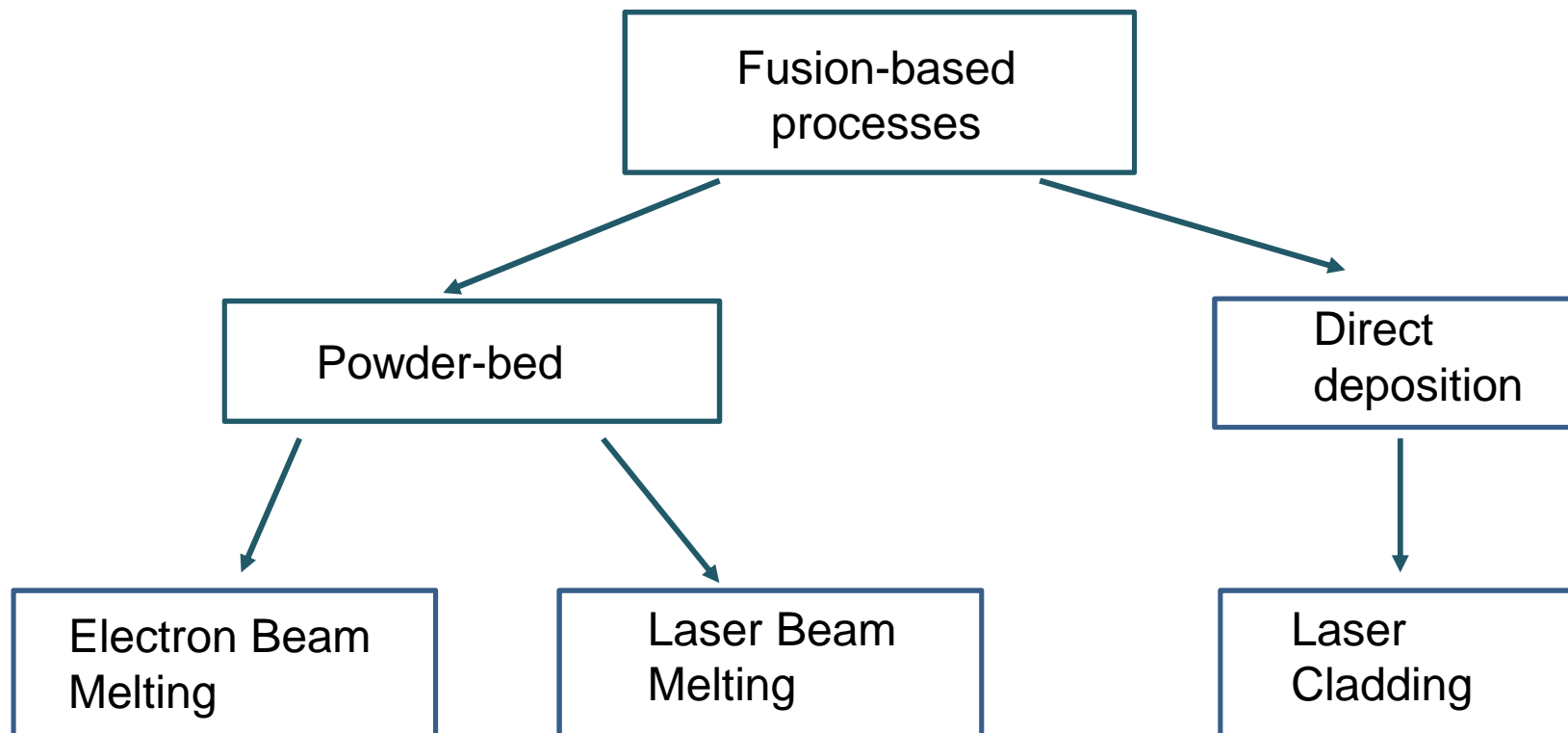

Raw material is mainly in powder form
Wire may also be used (less frequently)

Laser Beam Melting

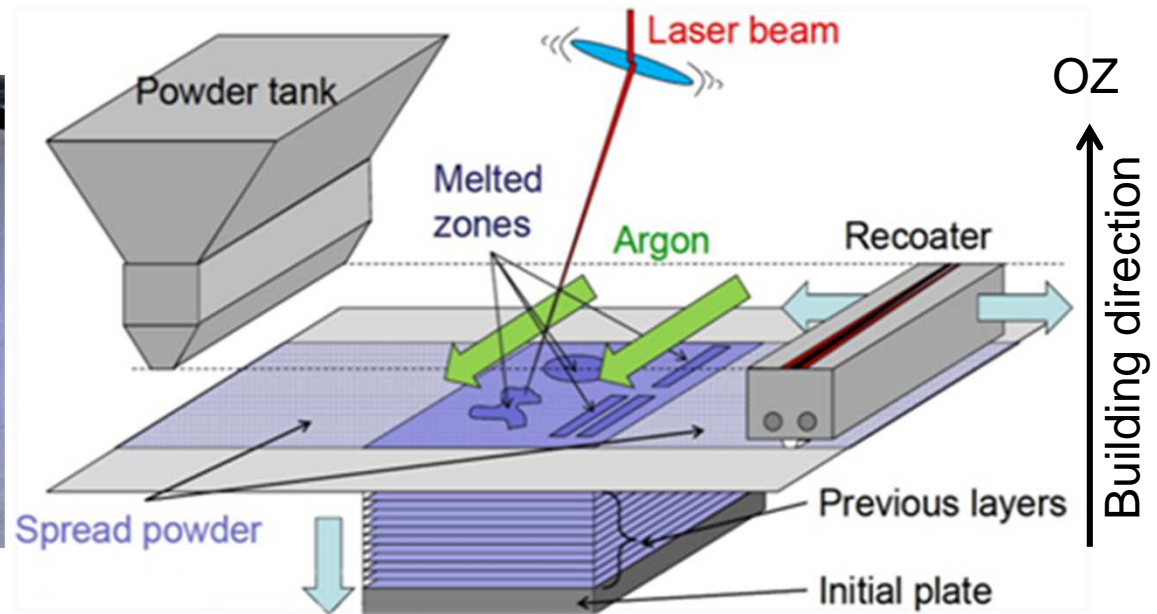
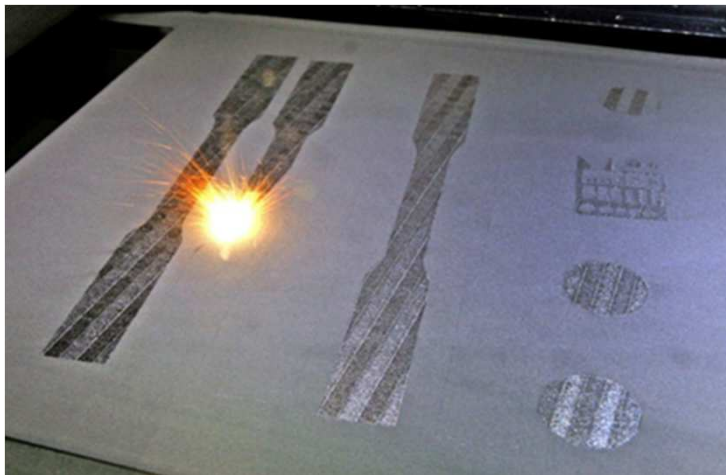

- Metallic powder is deposited layer by layer in a **powder-bed**...
- ... then molten locally by a laser according to the desired shape
- Suitable for making complex 3D shapes

Laser Cladding

- Metallic powder is projected onto a substrate and simultaneously melted through a laser beam: **Powder-feed** process
- Suitable for **fabrication** and **repair**
- Not limited to planar surfaces
- ... but not so well suited for complex 3D shapes

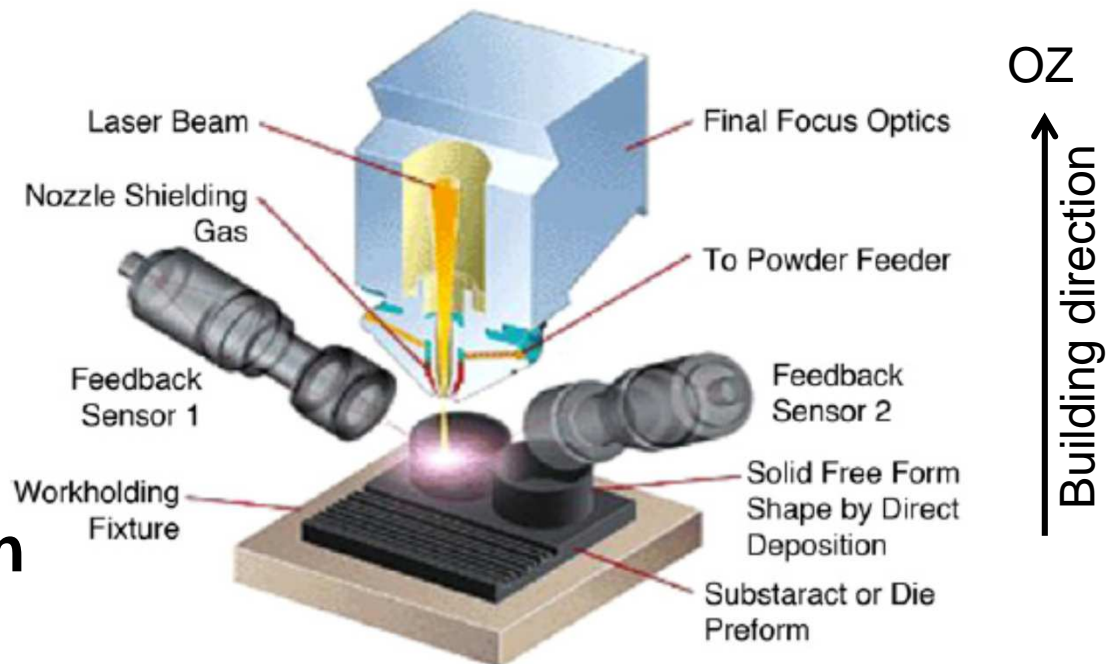

[Bhattacharya et al., 2011]

Laser Beam Melting (LBM) vs Laser Cladding (LC)

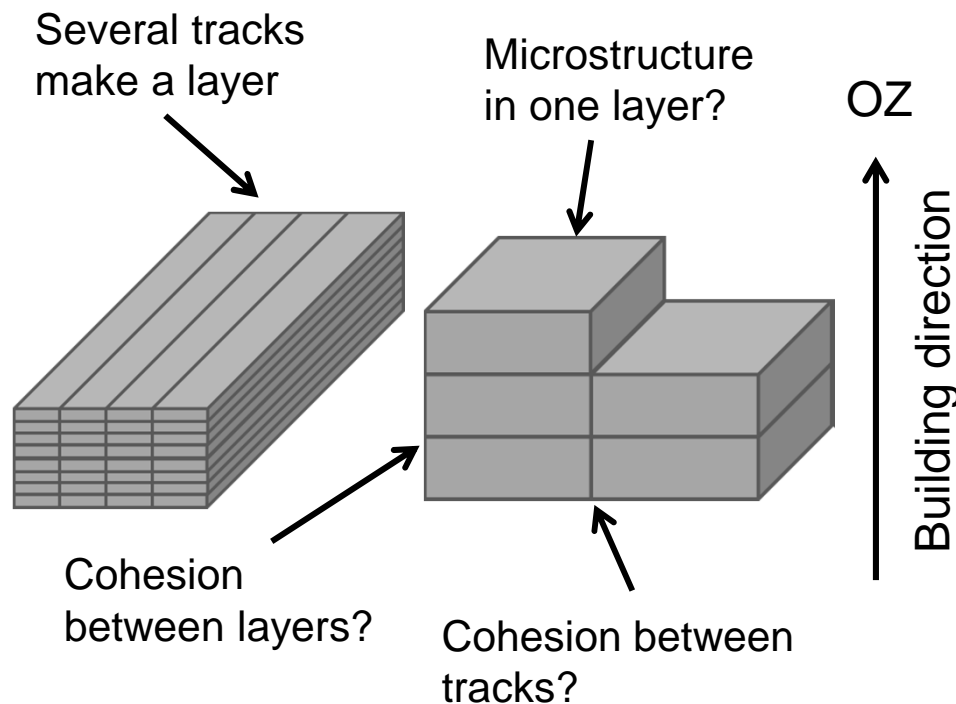

- Formation of defects: porosities, inclusions, oxides... ?
- Specificities of additive manufacturing for metallic materials
⇒ microstructures and properties

Complex thermal history

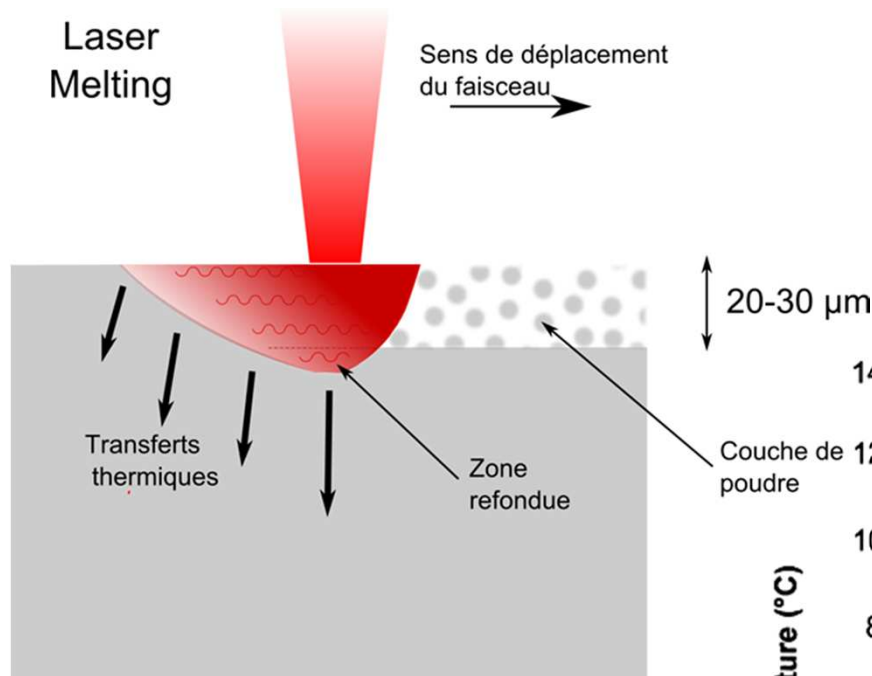

[Q.Contrepois, ULg]

Peak due to first melting

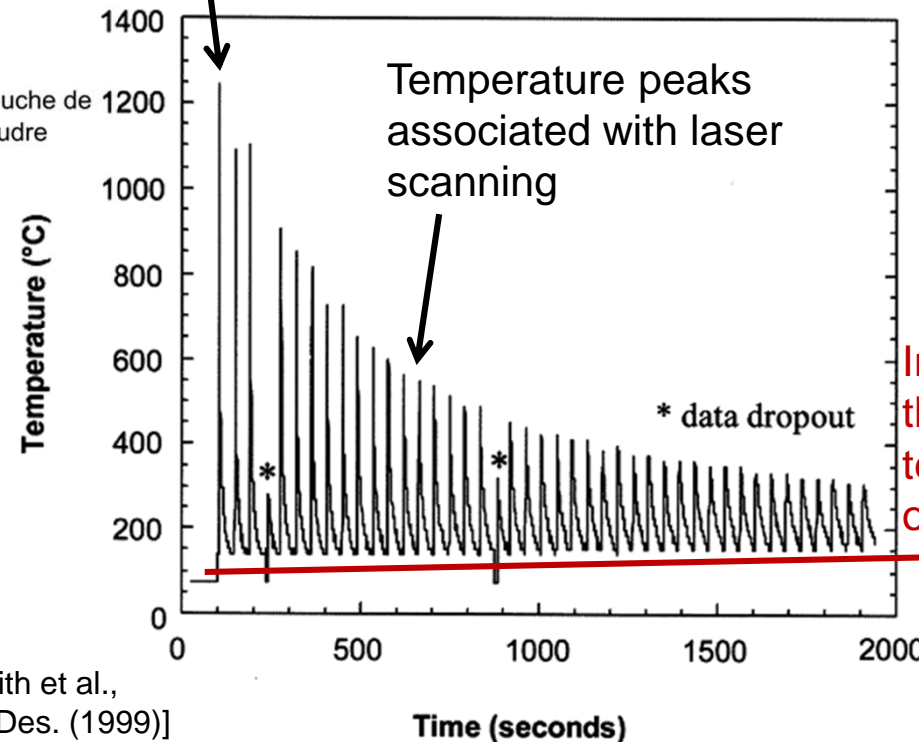

[M.L.Griffith et al.,
Mater. & Des. (1999)]

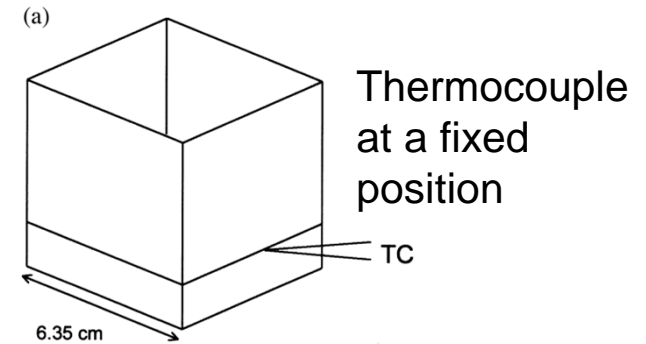

Complex thermal history

- Very high cooling rates
 - Build up of high internal stresses
⇒ Cracks, Deformations
 - Thermal history may vary locally as a function of the position inside a part
⇒ Microstructure may vary locally
⇒ Mechanical properties may vary locally!

Ti6Al4V, LC
Local hardness

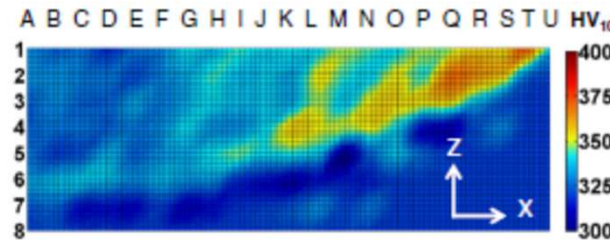

[Paydas et al., 2015]

- Out-of-equilibrium microstructures
e.g. chemical segregation at a very local scale

Tool steel, LC

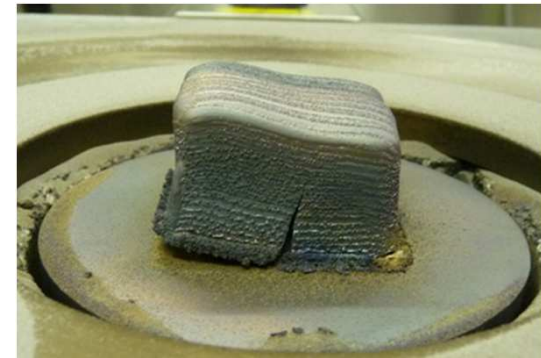

[N.Hashemi, ULg]

Microsegregation of Cr in stainless steel, LBM

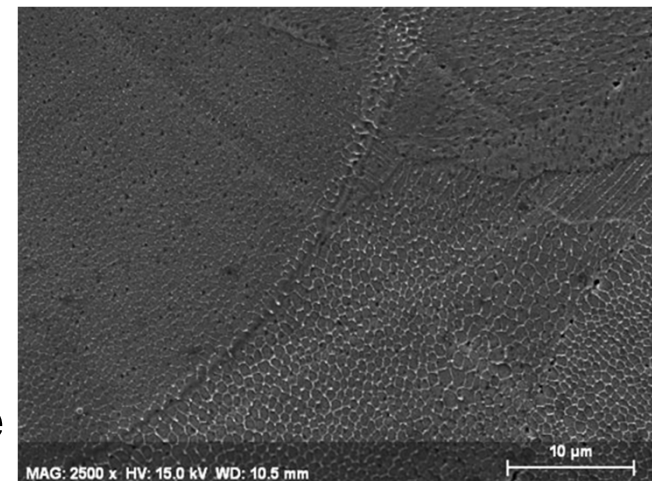

[Mertens et al., 2014]

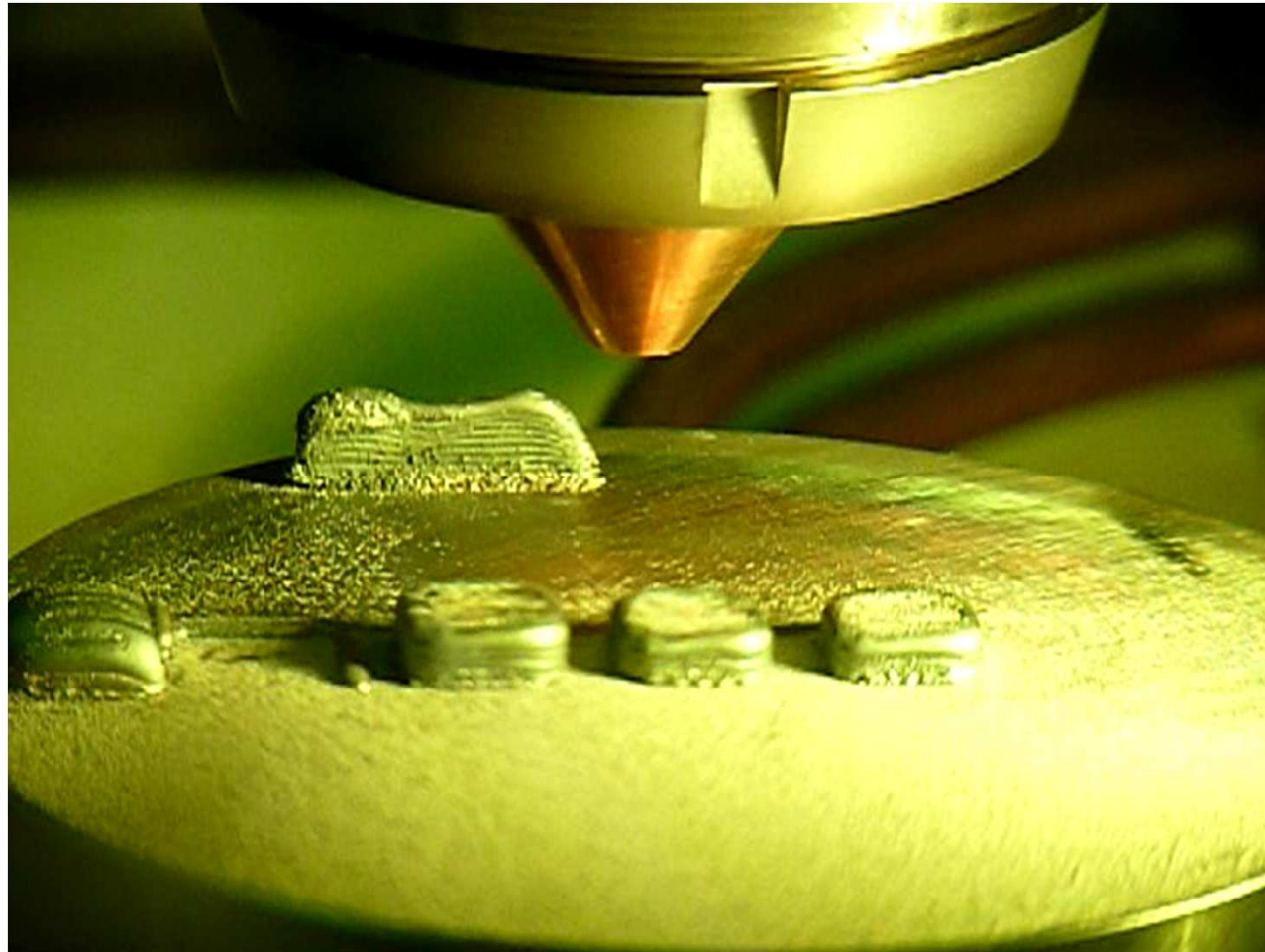

LBM and LC are **directional** processes (1)

- Formation of defects with particular orientations
- Cohesion between successive layers: a good wetting is important
⇒ **Partial remelting of the previously solidified layer**
- Cohesion between neighbouring tracks
⇒ **Tracks overlap, stability of the melt pool**

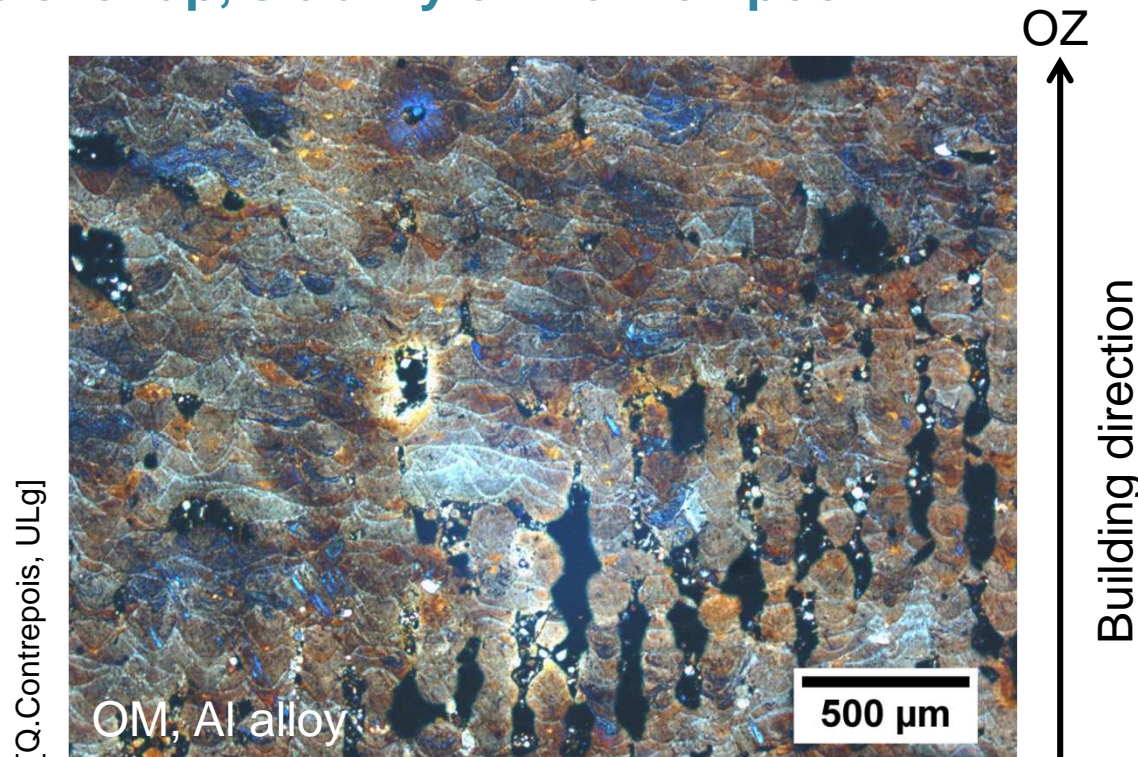

LBM and LC are **directional** processes

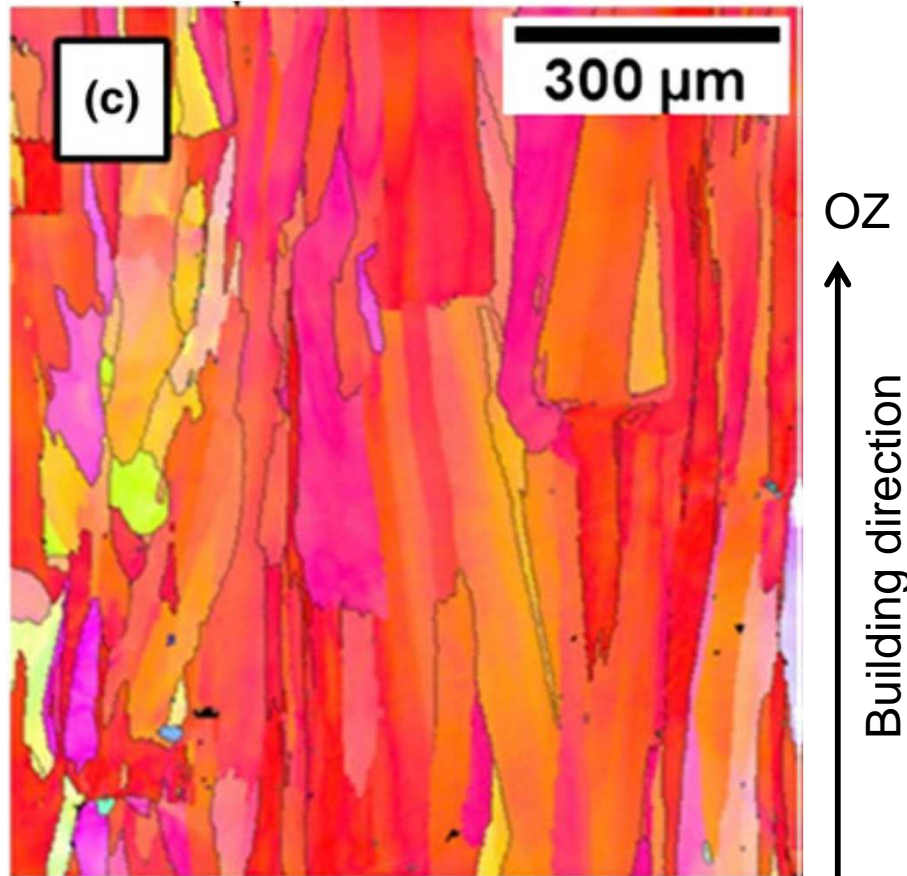

[Niendorf et al., 2013]

EBSD, Stainless steel

- Particular solidification processes may occur for **some materials and processing conditions**:
 - ⇒ **Epitaxial growth** // to the direction of maximum heat conduction i.e. the newly solidified layer crystallizes in the continuity of the previously solidified layer thus forming **elongated columnar grains**.
 - ⇒ **Anisotropy!**

Laser Beam Melting (LBM) vs Laser Cladding (LC)

- Many similarities...
- ... and a few important differences

	LBM	LC
Complex geometry	Yes	No
Thermal transfer	Conduction through the consolidated part Conduction through the powder bed (lower!)	Conduction through the consolidated part Convection/radiation on lateral surfaces
Processing parameters	Laser power, Scanning speed, Layer thickness, Hatch space, Preheating T	Laser power, Scanning speed, Hatch space, Preheating T, Powder feed rate Layer height is an outcome of the process !

Outline

- General introduction
 - What is Additive Manufacturing?
 - Advantages and drawbacks
 - Main A.M. processes for metals
- Current issues in the laser additive manufacturing of Ti alloy Ti6Al4V (Mono-material)
- Laser additive manufacturing of metal matrix composites (MMCs) (Multi-materials)

Current issues in the laser additive manufacturing of Ti alloy Ti6Al4V

Outline

- Background on Ti-6Al-4V
- Importance of thermal history
 - Defects and porosities (LBM and LC)
 - Dimensional accuracy (LC)
- Influence of laser power in LC Ti6Al4V
- Anisotropy in LBM Ti6Al4V
- Summary

Ti-6Al-4V

- Ti – 6Al – 4V first solidifies in the β (BCC) structure \Rightarrow Elongated columnar primary β grains
- Upon cooling, β transforms into α (hcp): Exact nature, morphology and size of the transformation products are function of cooling rate

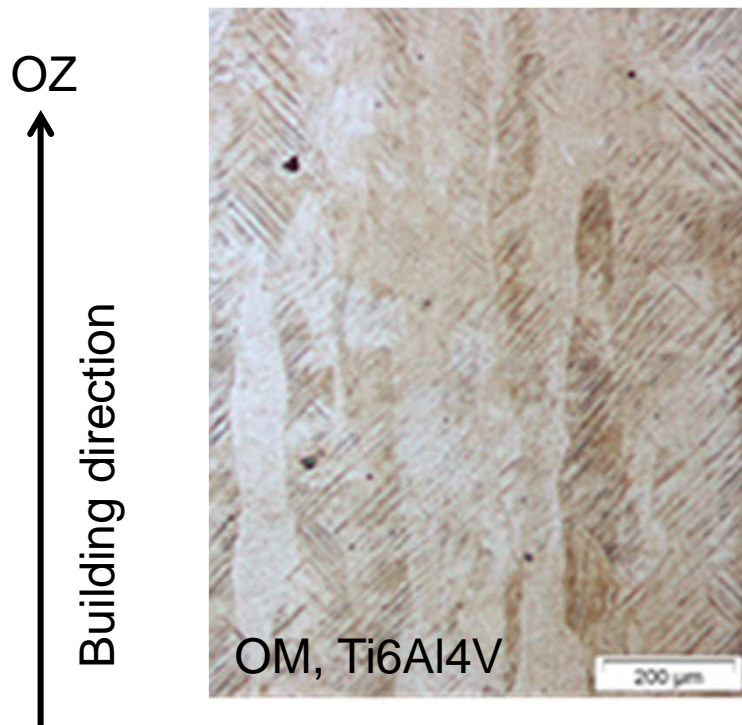

[Reginster et al., 2013]

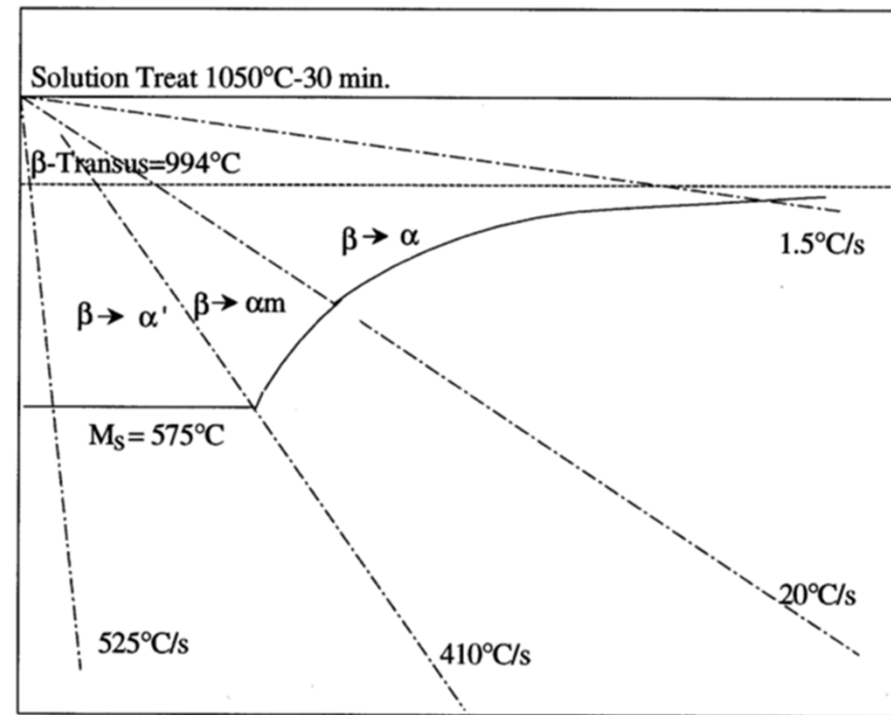

[Ahmed & Rack, MSEA, 1998]

Aims of the study

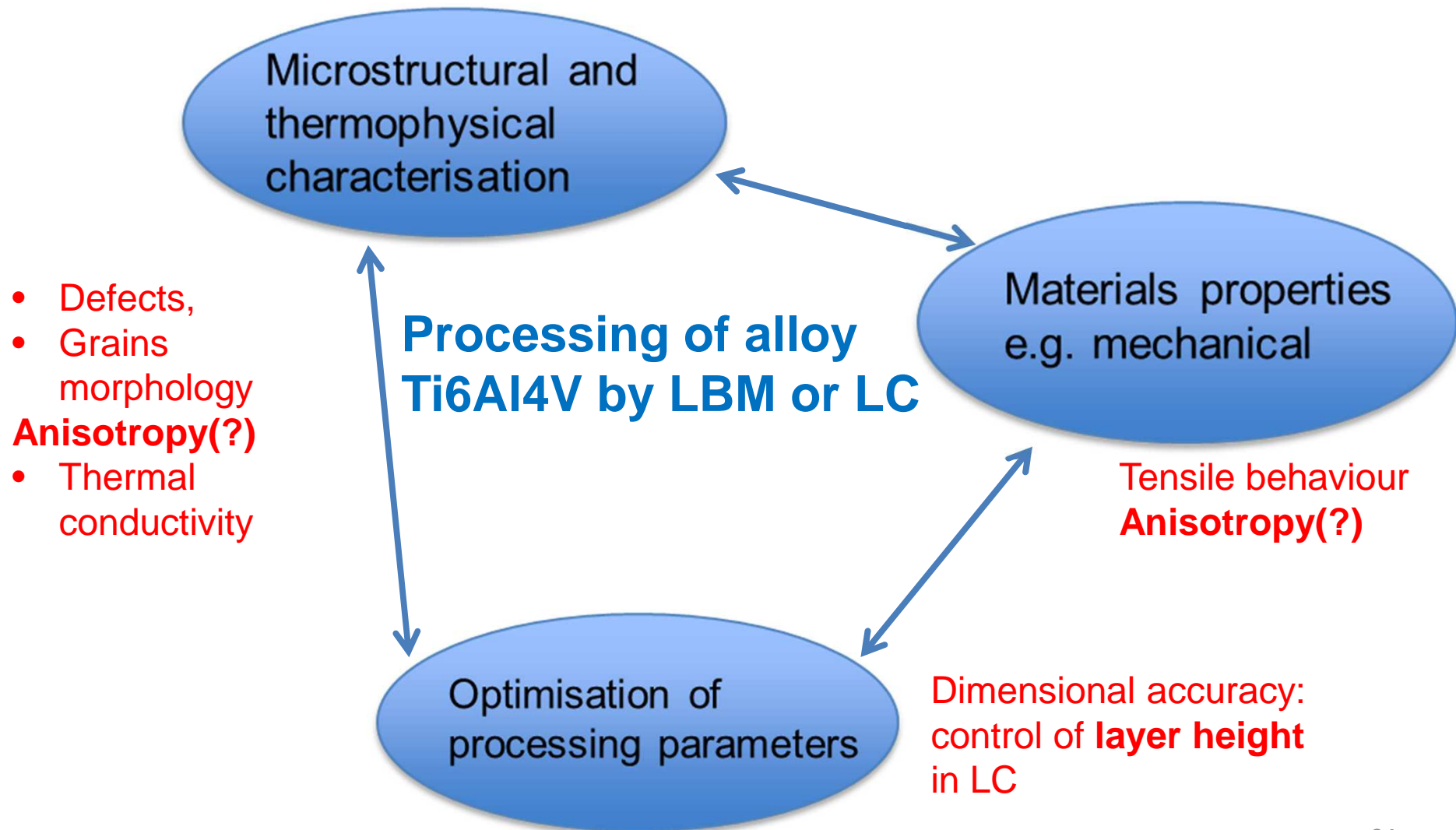

Outline

- Background on Ti-6Al-4V
- Importance of thermal history
 - Defects and porosities (LBM and LC)
 - Dimensional accuracy (LC)
- Influence of laser power in LC Ti6Al4V
- Anisotropy in LBM Ti6Al4V
- Summary

Thermal history (1) - Defects and porosities

Lack of fusion

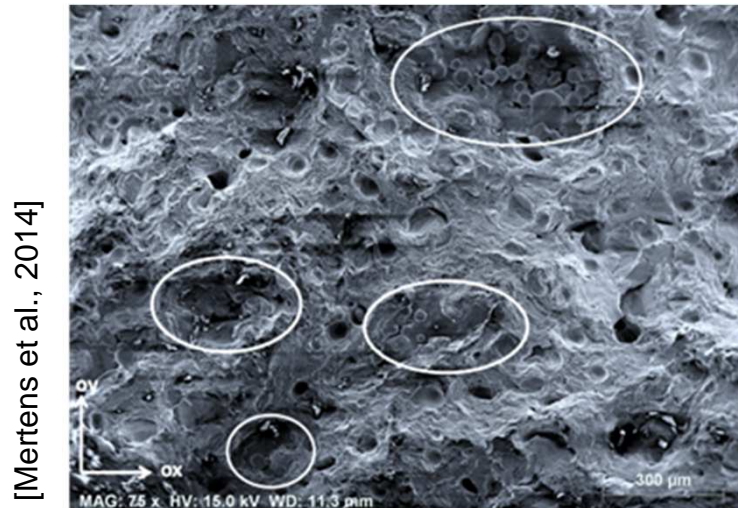

- Very detrimental for mechanical properties
- Processing conditions are **too cold!**

"Balling"

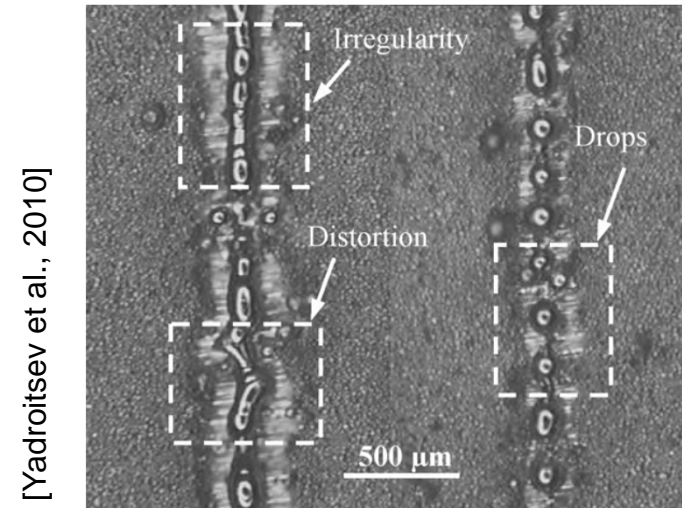

- Instability of the melt pool, due to an unfavourable combination of surface tension and viscosity
- This may happen because processing conditions are **too hot!**

Thermal history (2) - Defects and porosities

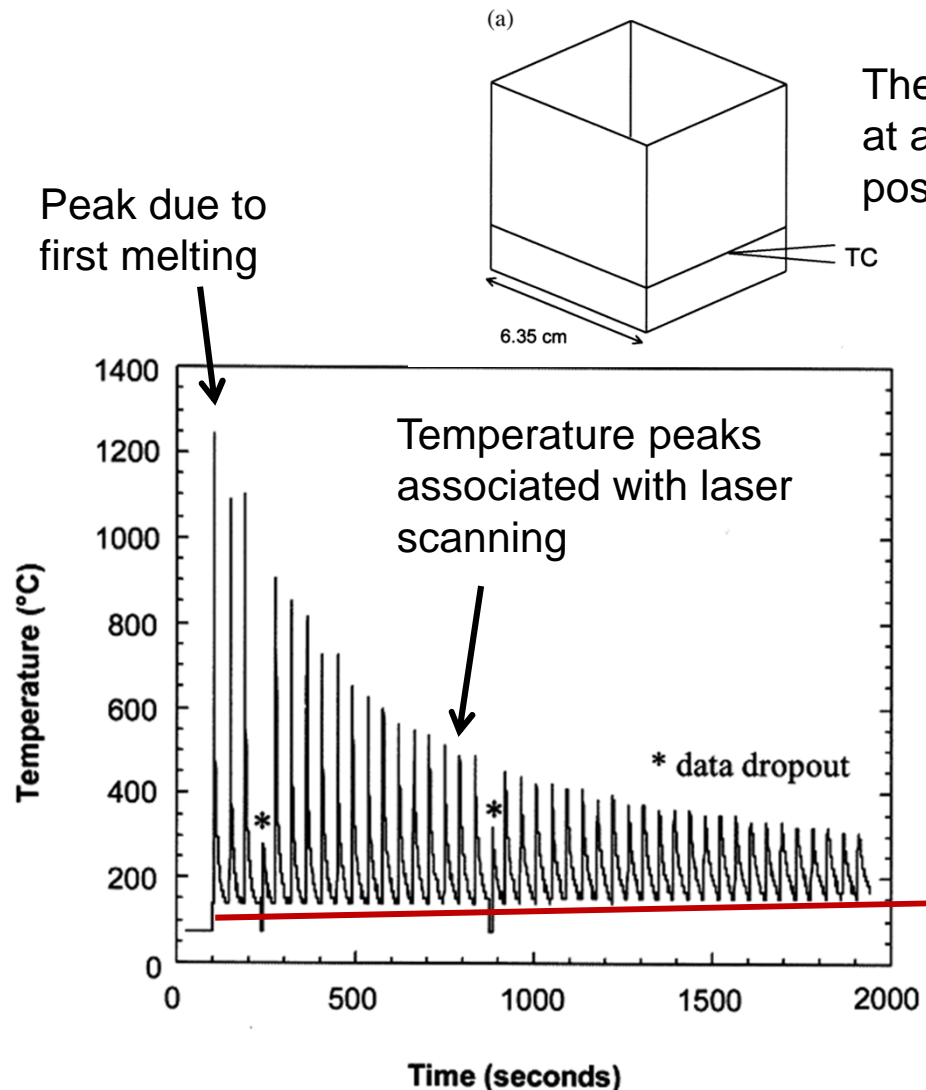

- Heat accumulation may cause "balling"
- One can try and adapt the processing parameters to limit heat accumulation...
- ... but not too much!
⇒ **Need for better optimized (path-dependent) processing parameters...**

Increase of the average temperature of the part

Thermal history (3) - Defects and porosities

⇒ ...Need for better optimized (path-dependent) processing parameters

- Knowing the temperature evolution during processing
 - Not that simple: absolute measurements possible only locally
 - Models for thermal transfer ⇒ **Thermal conductivity**

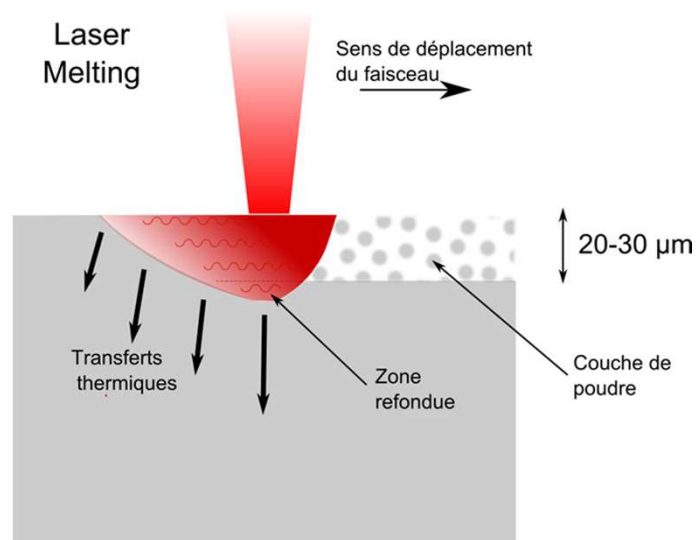

- Thermal conductivity values at room temperature are often used in FE models
- ... but the actual range of temperature during the process is much bigger: RT- T_{melt}

Thermal history (4) - Defects and porosities

- Determination of **thermal conductivity**

Laplace's Equation : $\chi(T) = \alpha(T) * \rho(T) * C_p(T)$

$\alpha(T)$ = thermal diffusivity,
(Laser Flash)

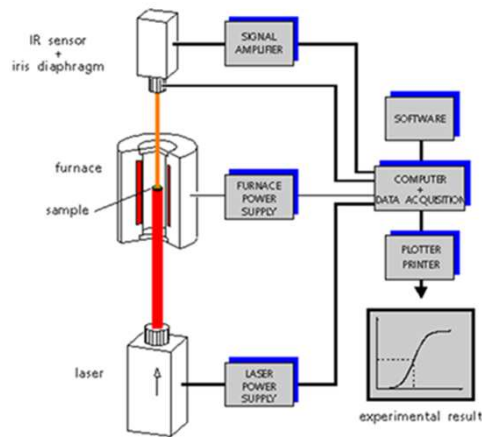

$\rho(T)$ = Density, (dilatometry also gives **CTE**)

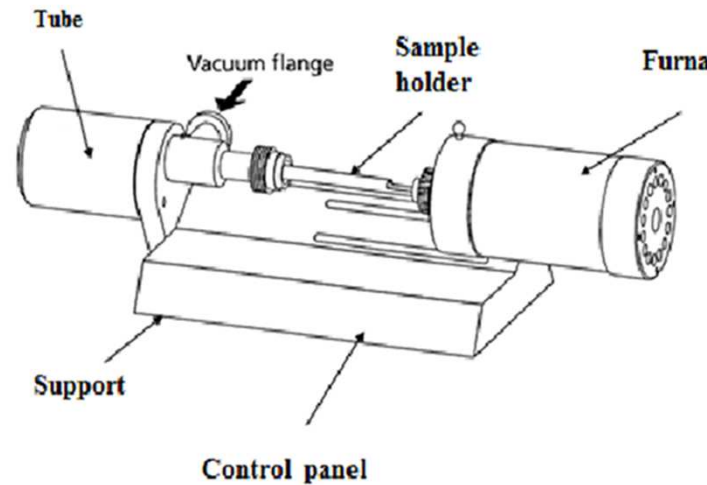

$C_p(T)$ = Specific heat, (DSC)

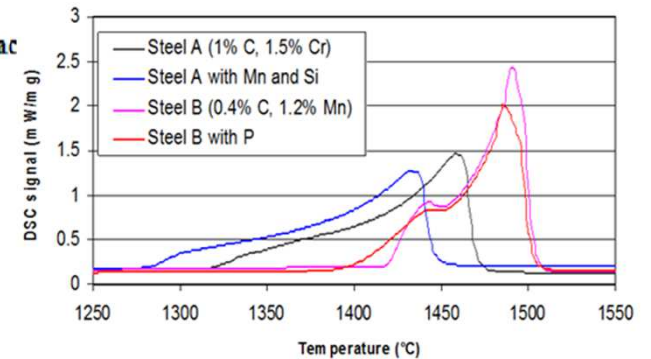

Thermal history (5) - Defects and porosities

⇒ ...Need for better optimized (path-dependent) processing parameters

- Knowing the temperature evolution during processing
 - Not that simple: absolute measurements possible only locally
 - Models for thermal transfer ⇒ **Thermal conductivity**

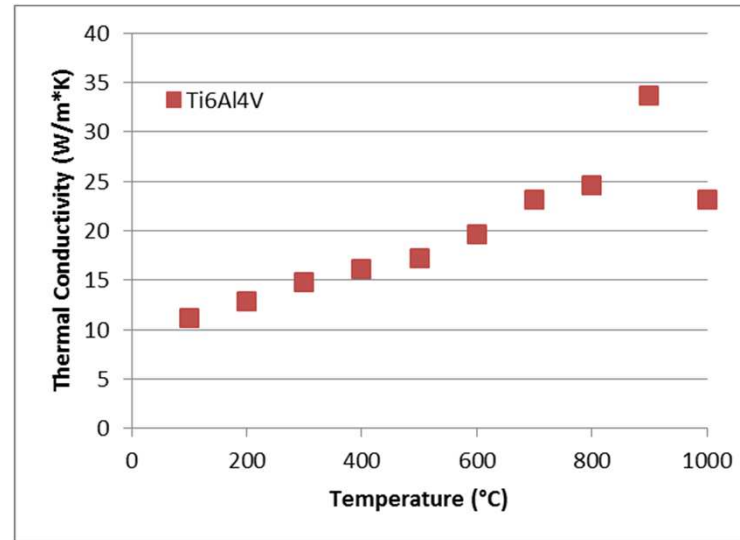
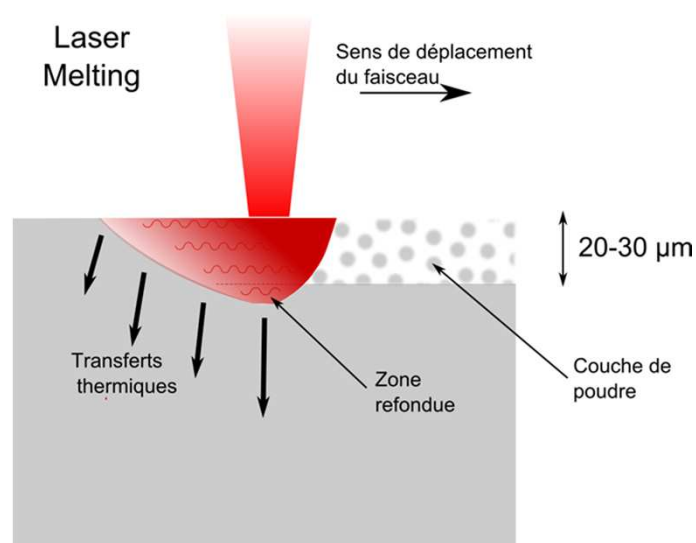

[Mertens et al., 2014]

⇒ **Thermal conductivity is strongly dependent on temperature!**

Thermal history (6) - Dimensional accuracy in LC

[N.Hashemi, ULg]

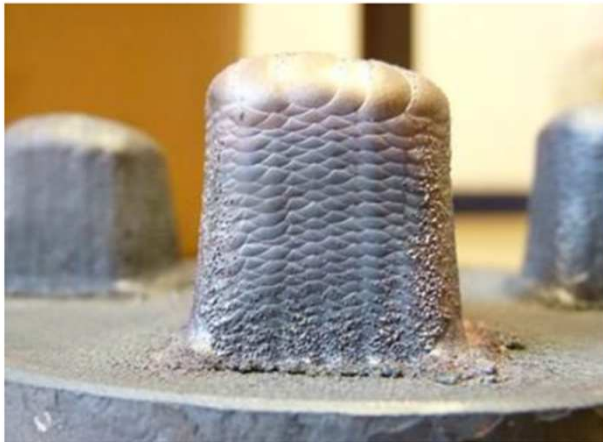

High Speed Steel, LC

Heat accumulates during processing

- ⇒ More powder is "captured" in the melt pool
- ⇒ Layer height varies as a function of local thermal history in each point
- ⇒ **Need for optimized (path-dependent) processing parameters to produce a deposit with a constant layer height**

e.g. HSS deposit with a target total height of 23 mm, and a target layer height of 0,7 mm



Laser power (W)	Measured total height (mm)	Measured layer height (mm)
940	26,1	0,79
1020	29,8	0,903

Outline

- Background on Ti-6Al-4V
- Importance of thermal history
 - Defects and porosities (LBM and LC)
 - Dimensional accuracy (LC)
- Influence of laser power in LC Ti6Al4V
- Anisotropy in LBM Ti6Al4V
- Summary

Influence of laser power in LC Ti6Al4V (1)

- High laser power are often preferred for high productivity

Laser power (W)	Scan speed (mm/min)	Incident energy (W*min/mm)	Building time (min)
1100	400	2,75	5,4
210	600	0,33	40

- But a high laser power also leads to coarser and more heterogeneous microstructure

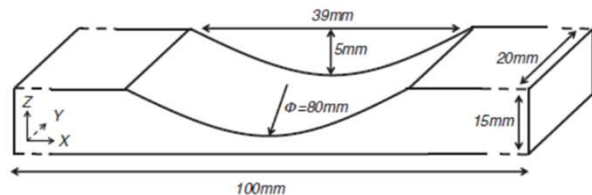

Laser power: 1100 W
Heat Affected Zone : ~1 mm !

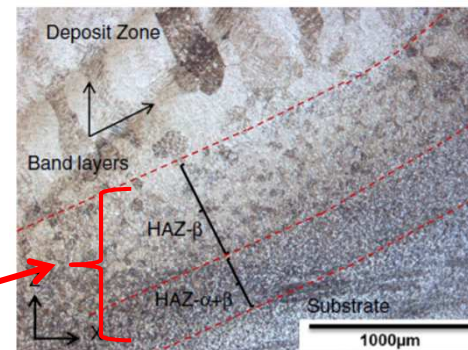

[Paydas et al., 2015]

- Investigating the potential of using a low power laser source
 - New 300 W source, installed beside the original 2kW source
 - Effect on microstructures and on process flexibility?

Influence of laser power in LC Ti6Al4V (2)

- Fabrication of thin walls by superposing single tracks
- Decreasing the laser power decreases the wall thickness

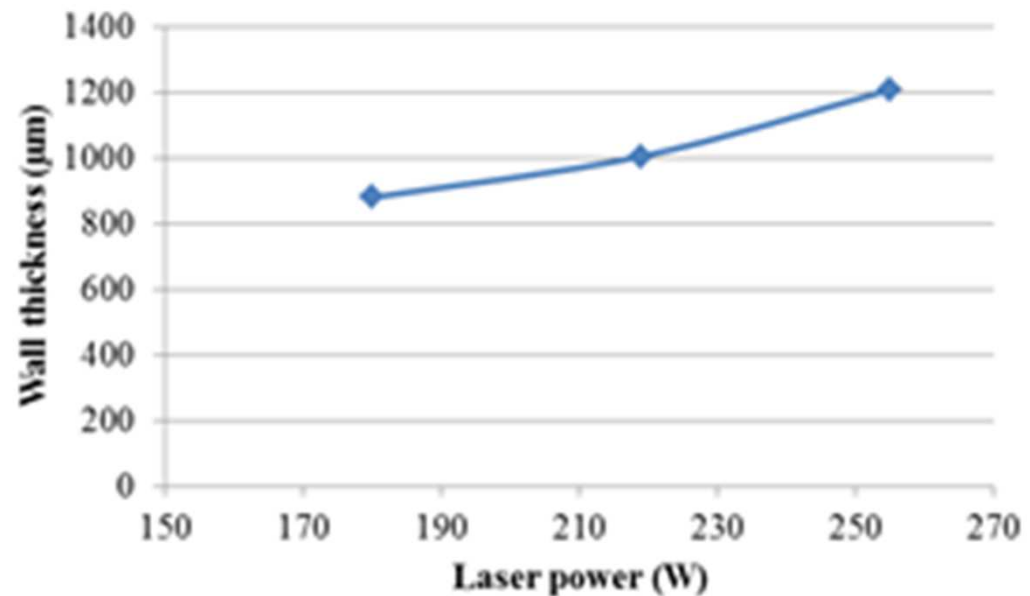
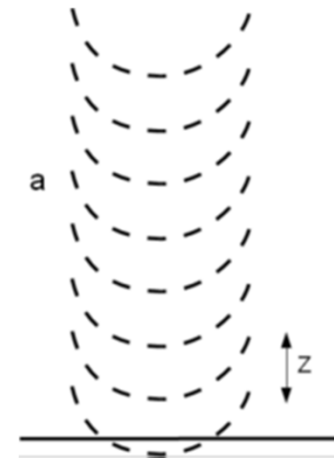

[Mertens et al., 2015]

Influence of laser power in LC Ti6Al4V (3)

"Refilling" a cup = Repair

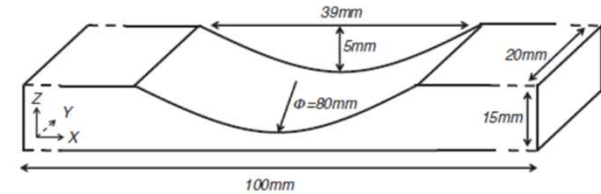

1100 W

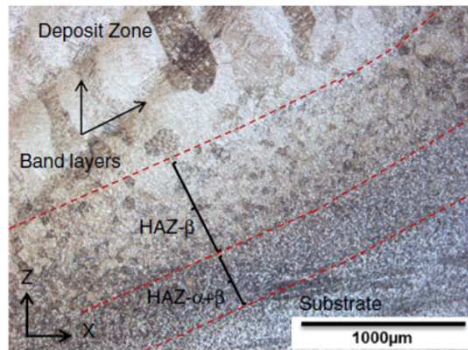

210 W

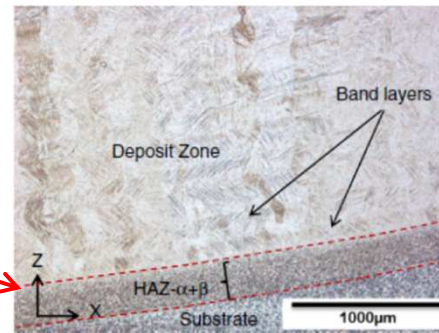

[Paydas et al., 2015]

Smaller HAZ

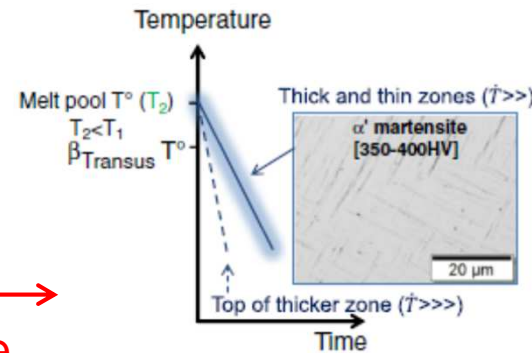
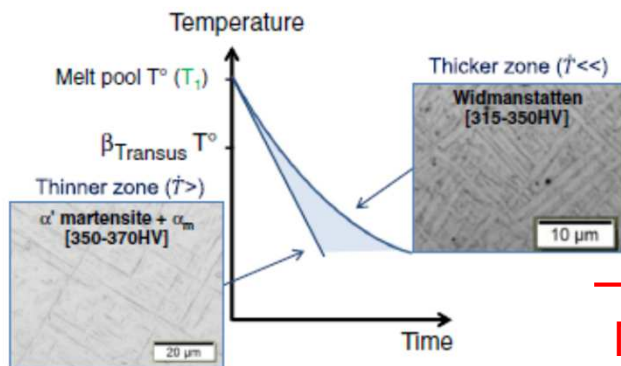

Microstructure is more homogeneous

Local hardness

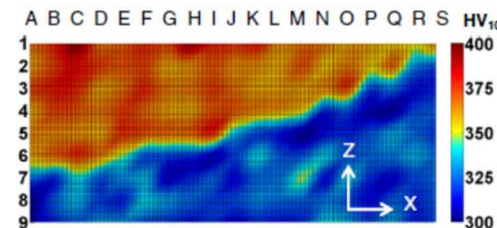
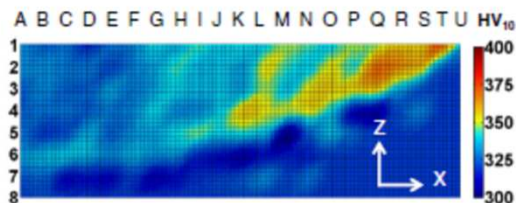

Outline

- Background on Ti-6Al-4V
- Importance of thermal history
 - Defects and porosities (LBM and LC)
 - Dimensional accuracy (LC)
- Influence of laser power in LC Ti6Al4V
- Anisotropy in LBM Ti6Al4V
- Summary

Anisotropy in LBM Ti6Al4V (1)

- Laser Beam Melting:

Layer thickness (μm)	Focus offset (mm)	Laser power (W)	Scanning speed (mm/s)	Hatch spacing (μm)
30	2	175	710	120

- Samples produced in three directions (anisotropy?)
- Ar flowing in the ox direction
- Rotation of the scanning direction between layers

- Microstructural characterisation :
Optical microscopy, Scanning Electron Microscopy
- Uniaxial tensile testing (anisotropy?)

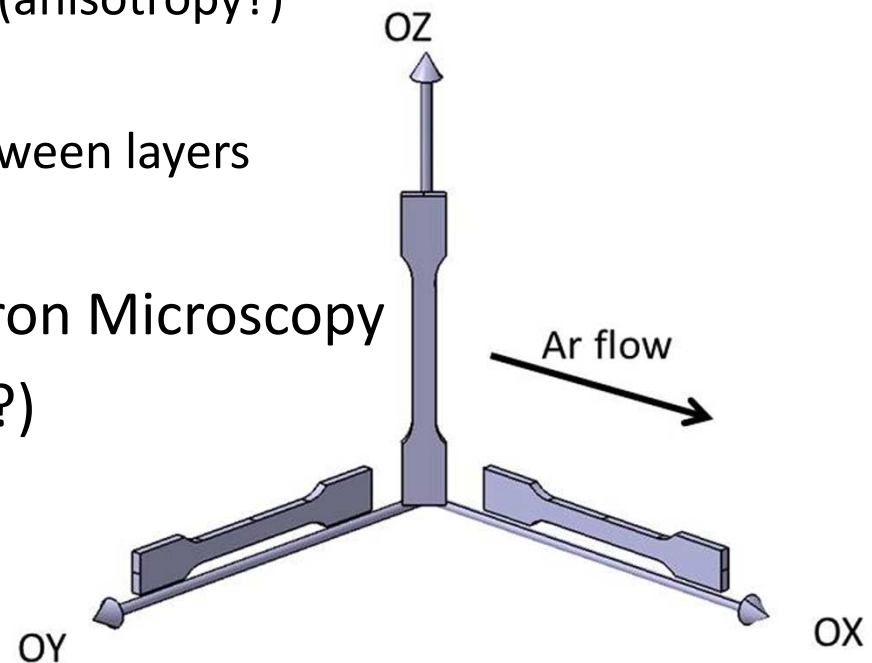

Anisotropy in LBM Ti6Al4V (2)

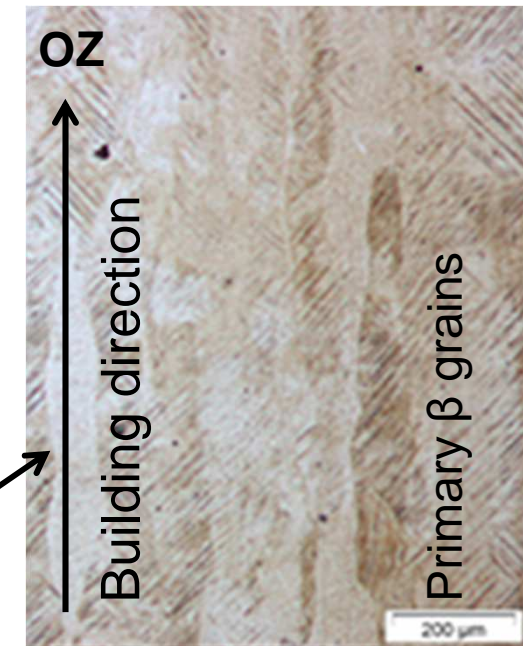
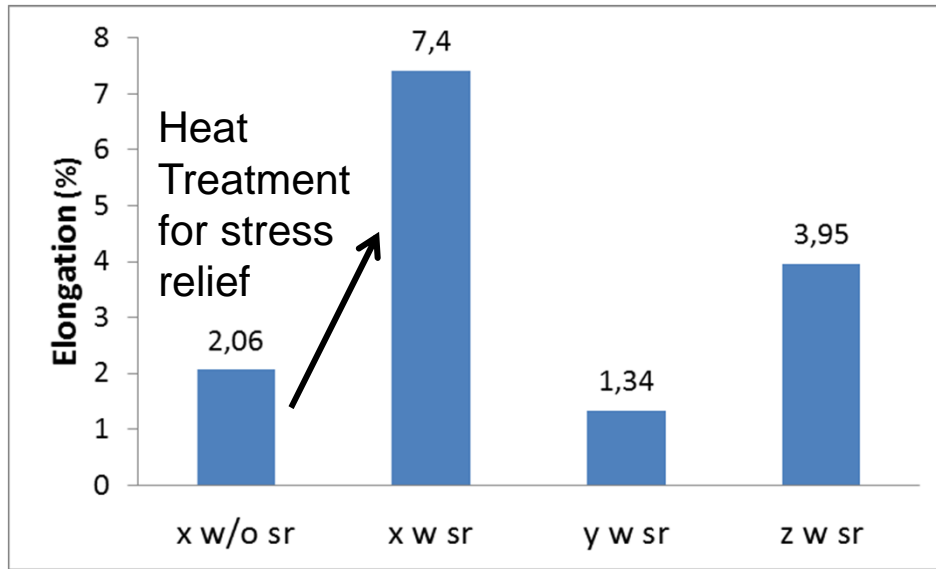

- LBM is a directional process
 - Epitaxial growth
- Strong anisotropy in building direction and **inside the deposition plane**
 - Cracks with specific orientation in the OY and OZ samples
 - Correlation with the microstructure ?

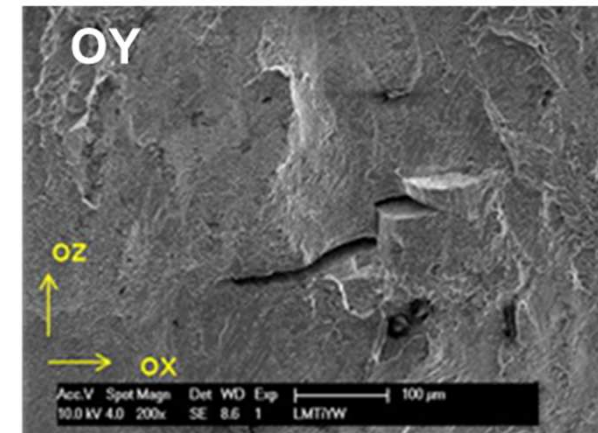

[Mertens et al., 2012]

Ti-6Al-4V (4) – microstructures

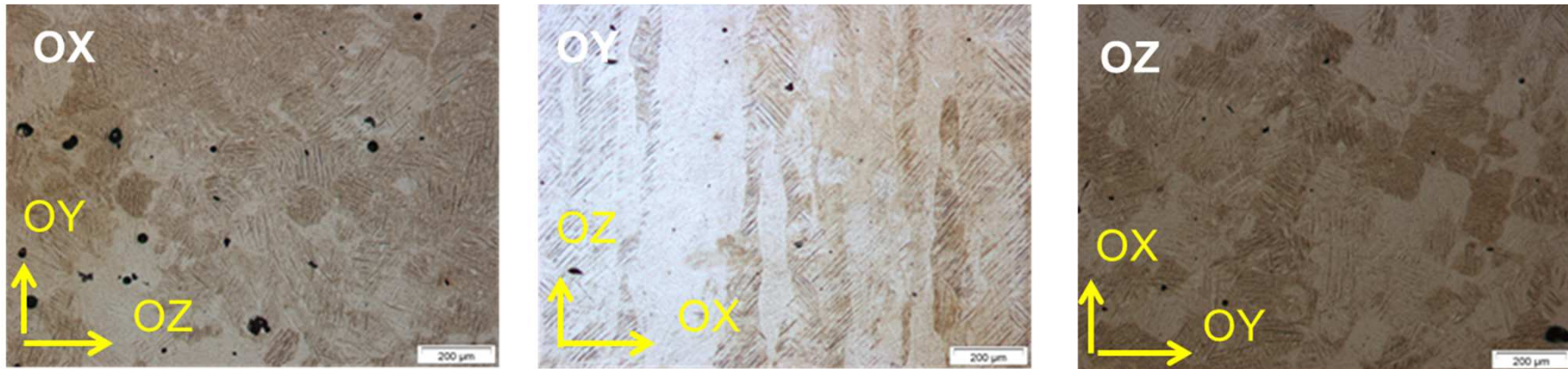

- Spherical porosities due to entrapped gas < 0,5 %
- Elongated primary β grains ($//$ OZ) in the OY sample...
- ...but not in the OX sample, suggesting that the grains are actually **tilted** with respect to the building direction
- Primary β grain boundaries or α/β interphase boundaries might play a role in fracture
⇒ Anisotropy in fracture behaviour could be related to the tilt in grains longest direction (?)

Ti-6Al-4V (5)

Anisotropy between α_x and α_y – Heat conduction

- Primary β grains grow following the direction of maximum heat conduction
- This direction for maximum heat conduction may become tilted with respect to the building direction
 - Scanning strategy

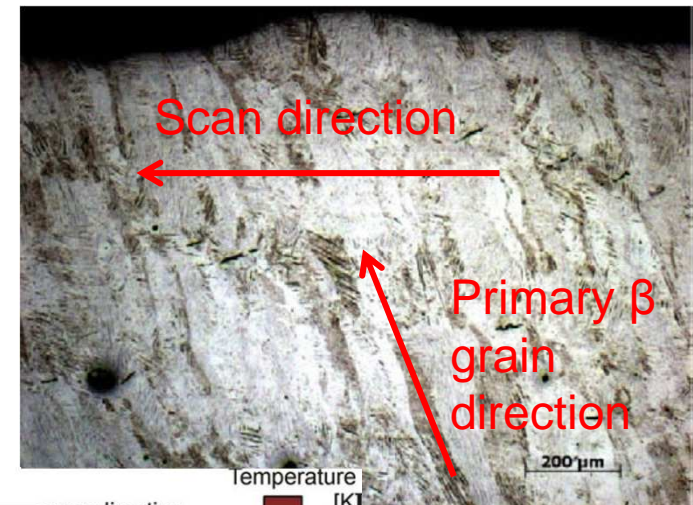
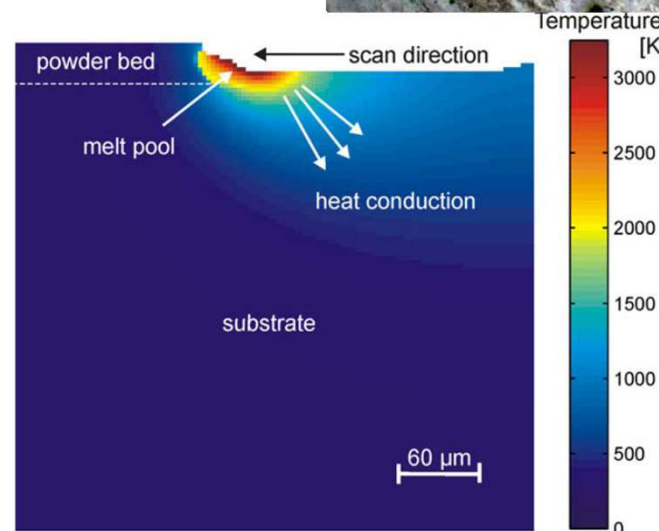
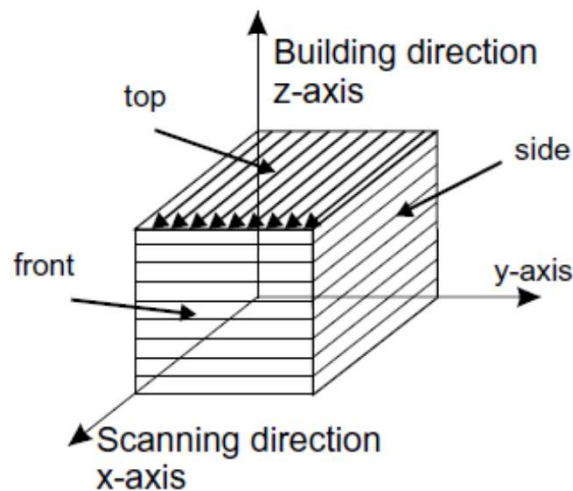

[Thijs et al.,
Acta Mater., 2010]

Ti-6Al-4V (6)

Anisotropy between ox and oy – Heat conduction

- Primary β grains grow following the direction of maximum heat conduction
- This direction for maximum heat conduction may become tilted with respect to the building direction
 - Scanning strategy: no, rotation!



- Scanning velocity
- **Geometry of the part**
- **Evaporation phenomena:**
Effect of Ar flow

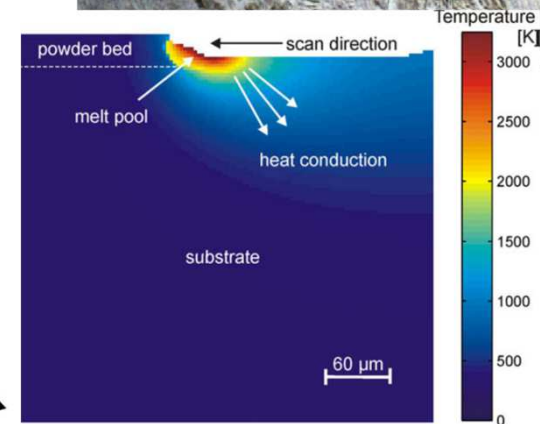
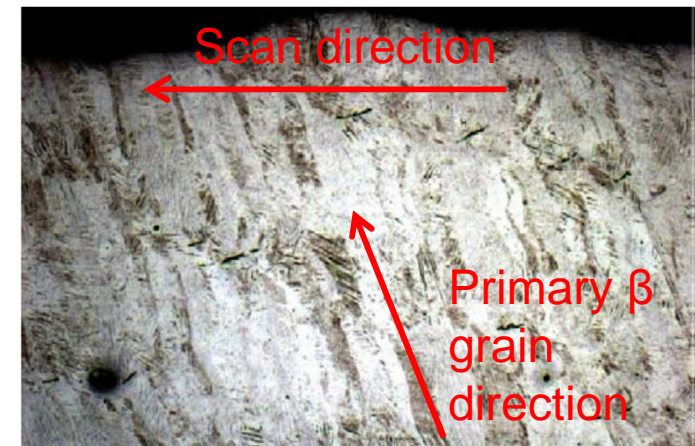
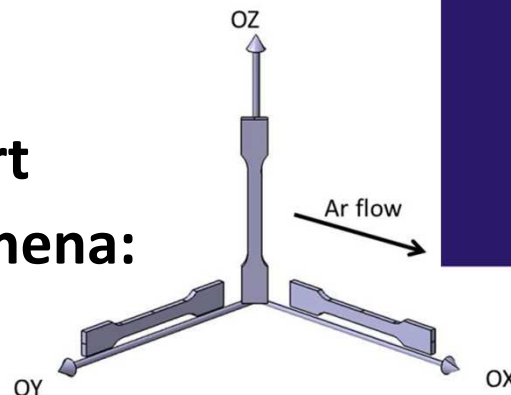

[Thijs et al., 2010]

Summary

- Laser Additive Manufacturing technologies are strongly directional processes, characterised by ultra-fast thermal cycles. As a consequence, one might observe:
 - Internal stresses
 - Anisotropy of the microstructure and mechanical properties
- Local thermal history is of paramount importance to control
 - local microstructure
 - formation of defects
 - dimensional accuracy of the parts (particularly in LC by controlling the layer height)

Outline

- General introduction
 - What is Additive Manufacturing?
 - Advantages and drawbacks
 - Main A.M. processes for metals
- Current issues in the laser additive manufacturing of Ti alloy Ti6Al4V (Mono-material)
- Laser additive manufacturing of metal matrix composites (MMCs) (Multi-materials)

Laser additive manufacturing of Metal Matrix Composites (MMCs)

Introduction (1)

Metal matrix composites (MMCs)

Composite = a material, such as reinforced concrete, **made of two or more distinct materials** (Collins)

Composite = matériau formé de **plusieurs composants** élémentaires dont l'association confère à l'ensemble des **propriétés** qu'aucun des composants pris séparément ne possède (Larousse)

⇒ **New properties that none of the constituents would exhibit on its own.**

Introduction (2) Metal matrix composites (MMCs)

Self lubricating material exhibiting simultaneously a low friction coefficient and a low wear rate: hBN and MoS₂ in SS 316L

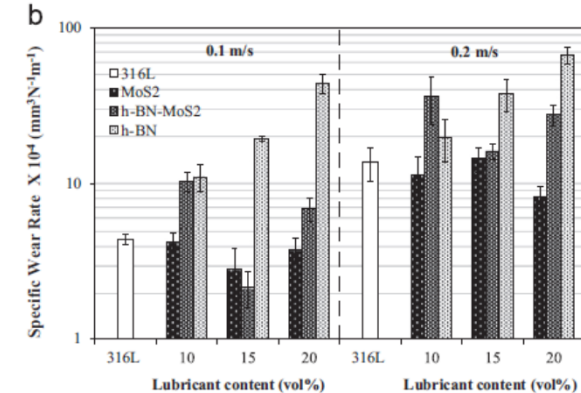
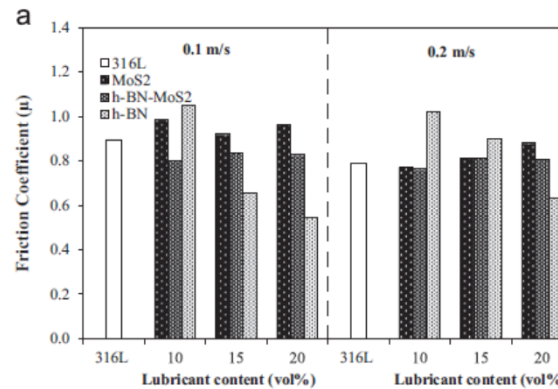

[Mahathanabodee, 2014]

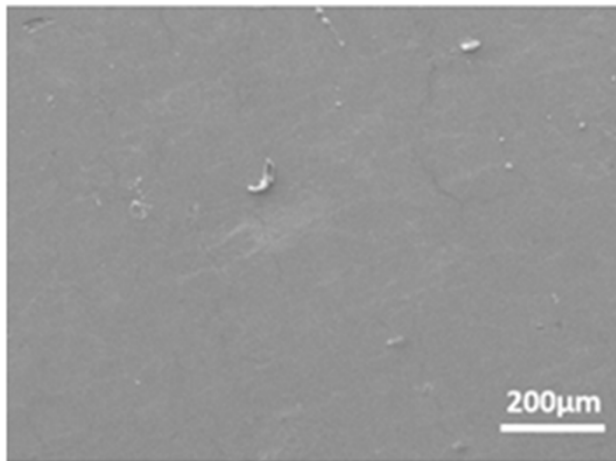

Nano Hydroxyapatite coating on SS 316L
Compatibility ensured through a graded SS 316L + nHA composite layer

[Wei, 2015]

Introduction (3)

(Powder-based) additive manufacturing of MMCs

- Allows the production of composite part with complex shape
- Potential for the production of 3D preform with optimised out-of-plane properties
- Limited to particulate reinforcements

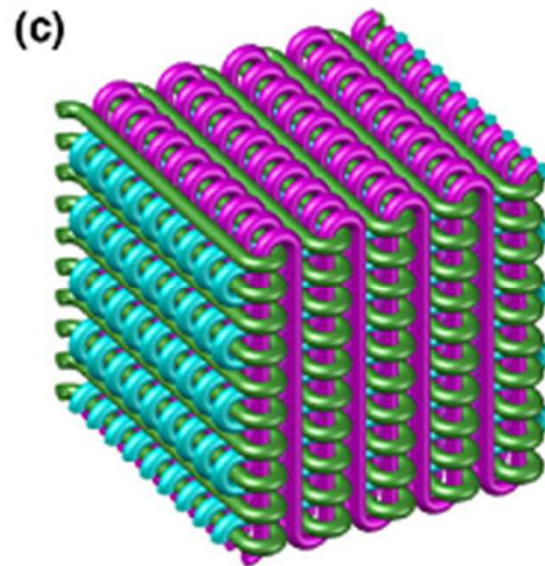

Introduction (4) (Powder-based) additive manufacturing of MMCs

- Laser Beam Melting
- Well suited for the production of MMCs with complex shapes
- Requires the pre-mixing of the reinforcement particles with the metallic powder
 - Risk: reinforcement particles may settle down due to difference in density leading to poor compositional control.

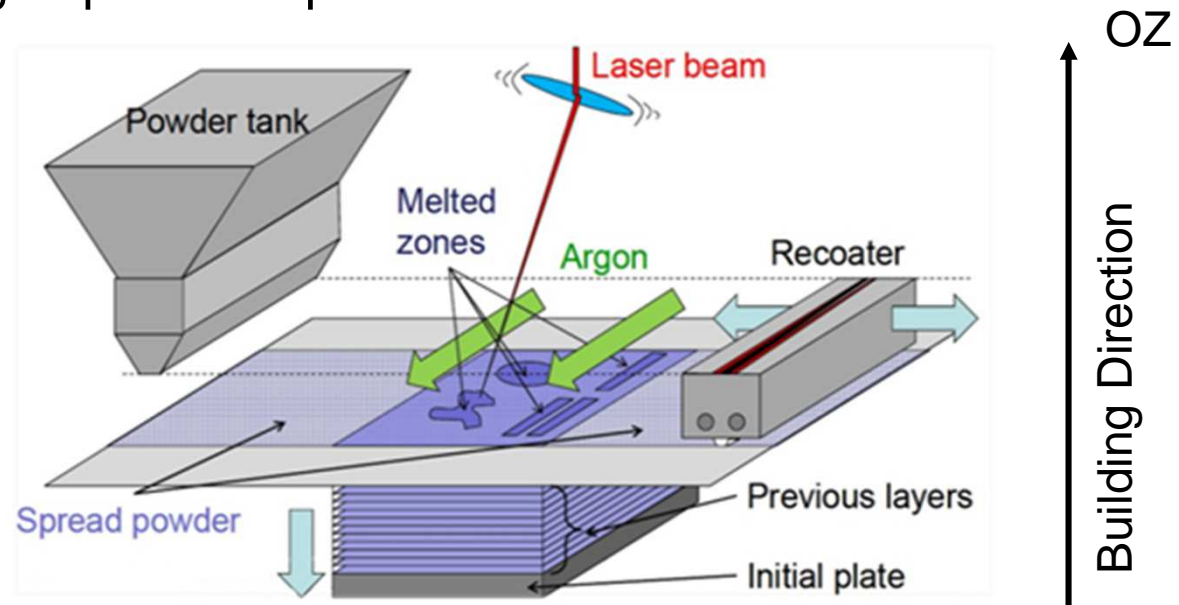

Introduction (5)

(Powder-based) additive manufacturing of MMCs

- **Laser Cladding**
- Not so well suited for the production of MMCs with complex shapes
- Pre-mixing of the reinforcement particles and metallic powder is possible but not compulsory
- Allows the production of Functionally Graded Materials

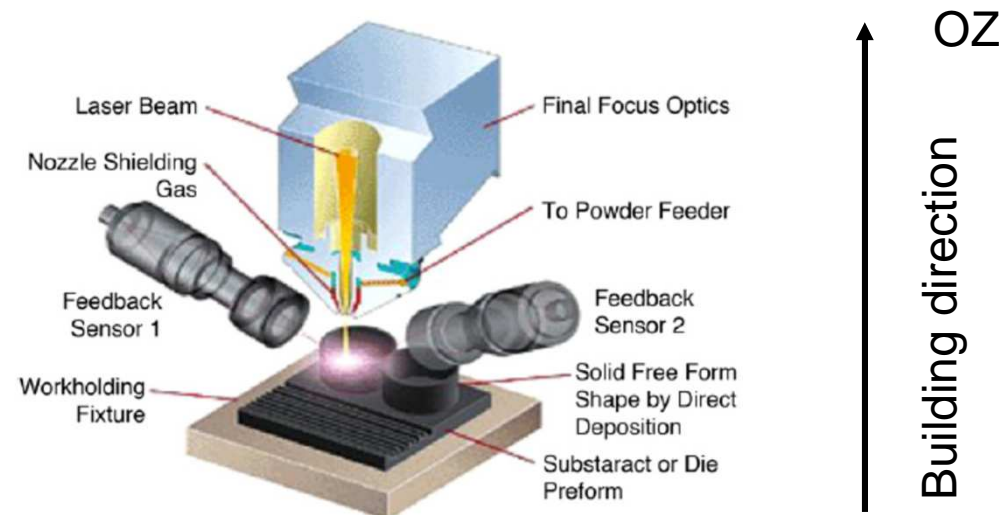

[Bhattacharya et al., 2011]

Introduction (6) – Laser Cladding Functionally Graded Materials

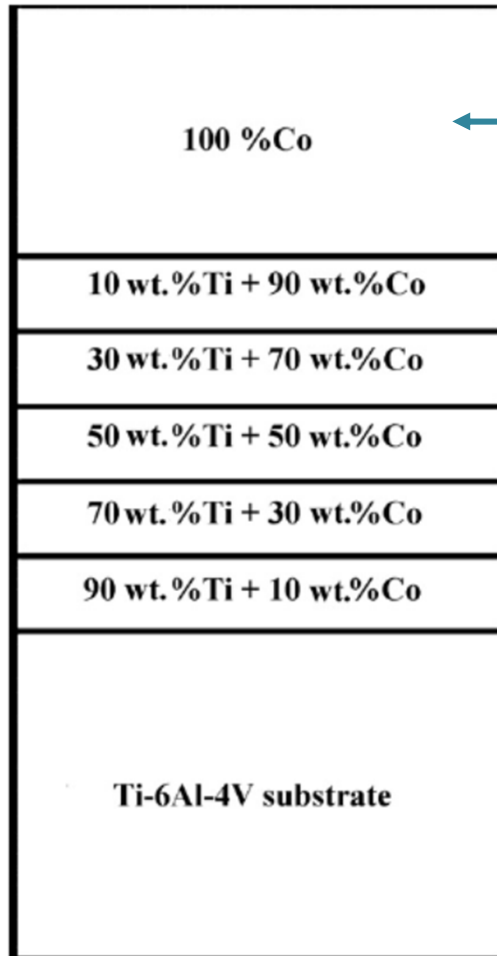

[Dutta Majumdar et al., 2009]

Better **biocompatibility**
(hip prosthesis)

Tissue regrowth

Optical Density of MTT Test

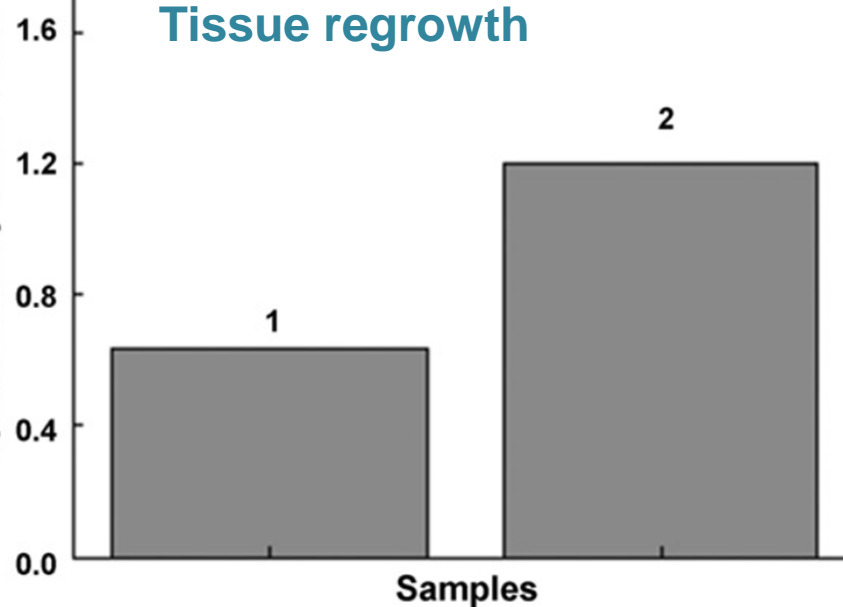

Ti6Al4V/Co

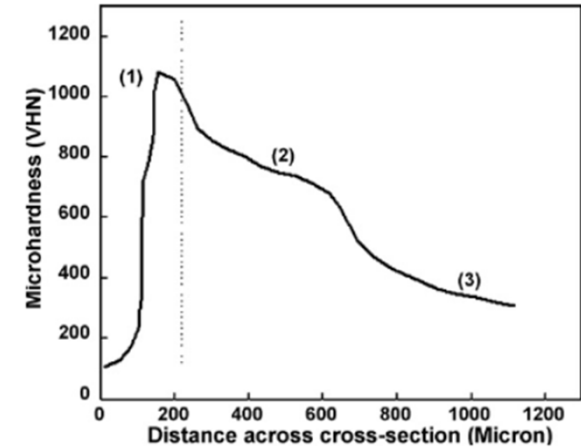

Hardness ↑↑

Introduction (9)

Objectives

- Investigating the processing of SS 316L matrix composites
 - With SiC particles
 - With WC particles
- Assessing the feasibility
- Requirements concerning the powders
- Stability of the reinforcement particles?
- Role of interfacial reactions, dissolution and secondary precipitation?

Outline

- Introduction
 - Metal matrix composites
 - Additive manufacturing for processing metal matrix composites
 - Objectives
- Experimental methods
- Results and discussion
 - Stainless steel 316L reference
 - SS 316L + SiC
 - SS 316L + WC
- Concluding remarks

Experimental procedure (1)

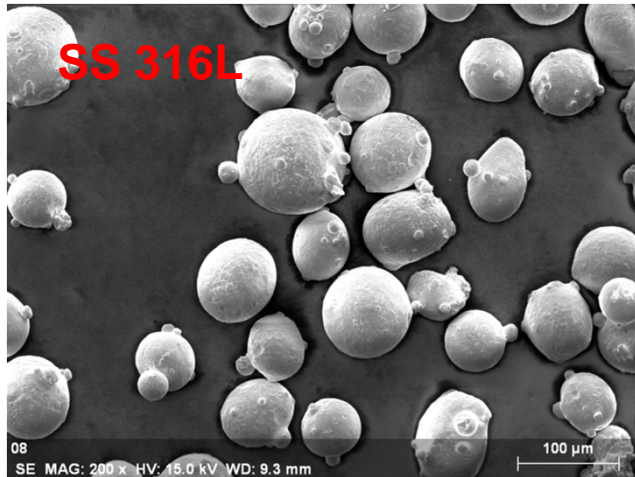

7 - 12 %

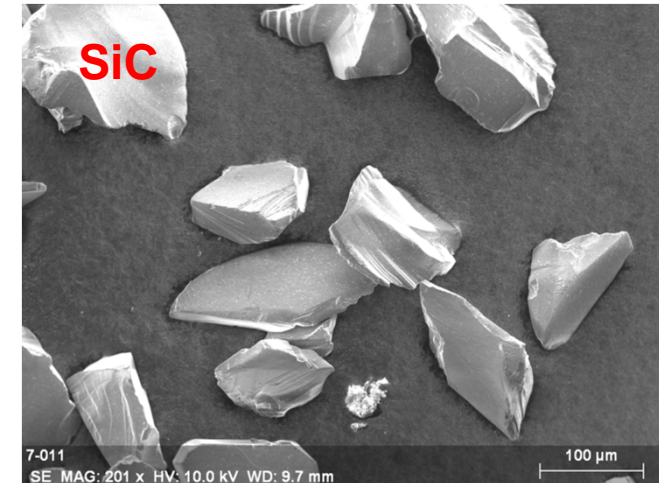

Thin coatings

OR

- SS 316L as substrate
- Irepa Laser Cladding System
 - Laser power = 500 – 680 W
 - Travel speed = 270 – 190 mm/s,
 - Layer thickness = 700 μm

16 – 47 %



Thick (15 layers) deposits

Experimental procedure (2)

- Microstructural observations were carried out by SEM, after etching with aqua regia (i.e. 55% HCl + 20% HNO₃ + 25% methanol)
- 20 kg Vickers hardness tests were used to assess local variations in microstructure and properties

Results and discussion (1)

Reference SS 316L deposits

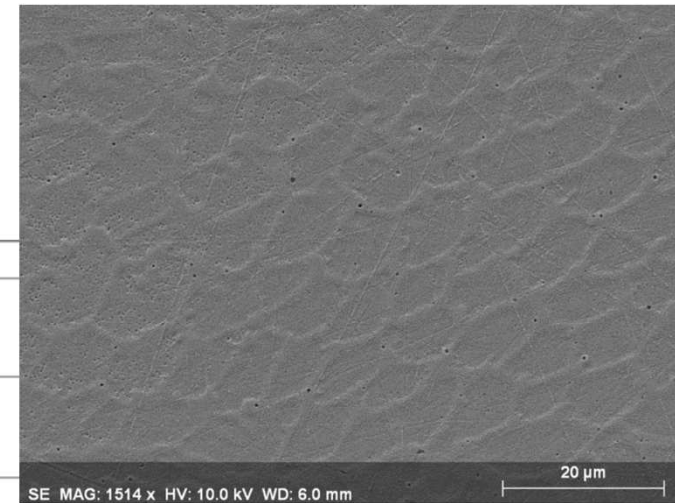
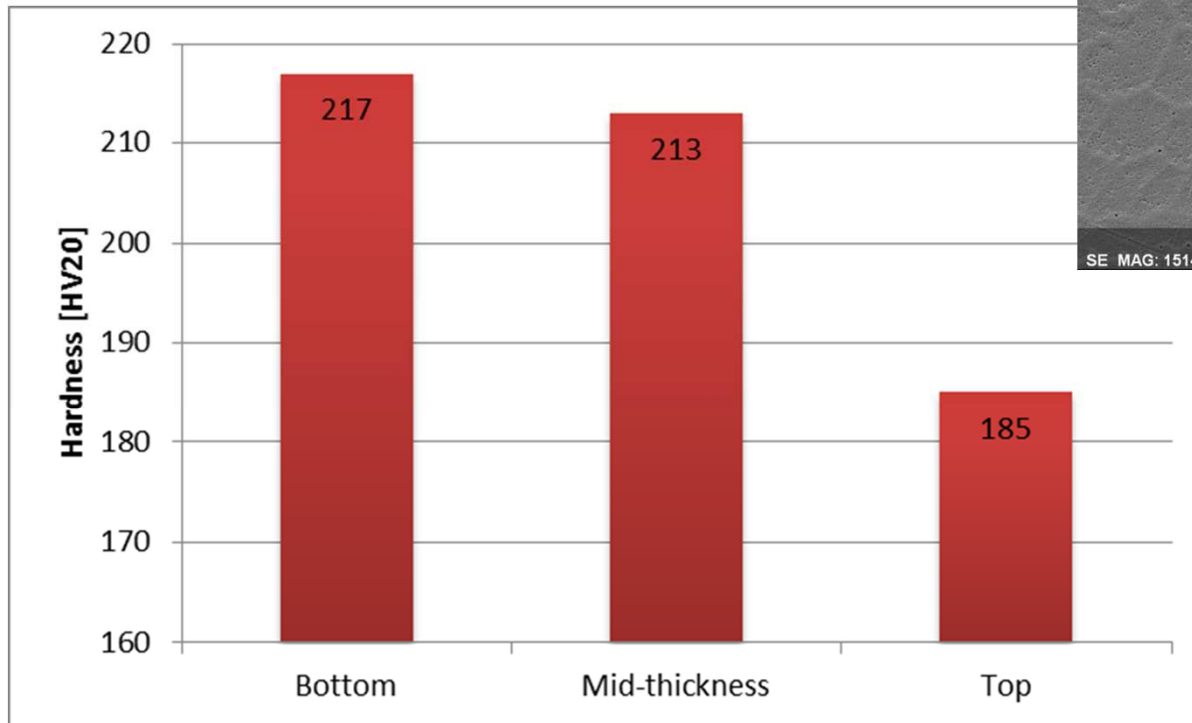

[Mertens et al., 2017]

- Typical fine cellular microstructure ~10 μ m
- Hardness varies as a function of position, in correlation with local variations of the thermal history

Heat accumulates during deposition, leading to some microstructural coarsening and loss in hardness

[Paydas et al., 2015]

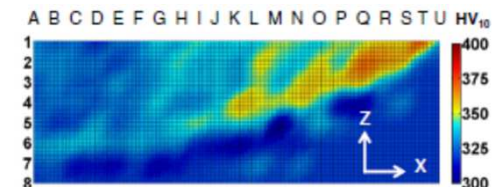

Results and discussion (2)

SS316L + SiC

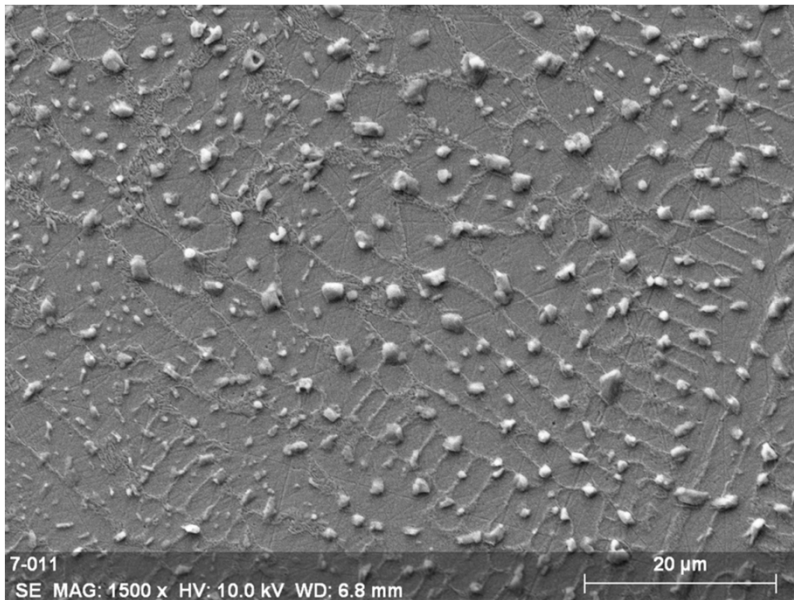

- **Extensive dissolution of SiC during laser cladding**
- Interdendritic spacing $\sim 3\text{-}4\ \mu\text{m}$
⇒ Microstructural refinement

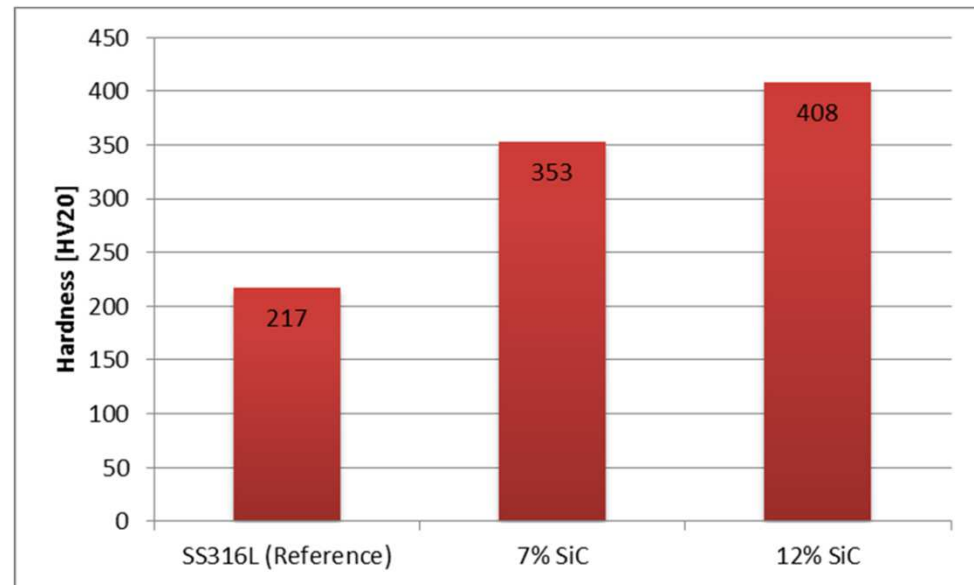

Hardness increases with SiC content

Improving the cavitation erosion resistance

SS 316 + WC

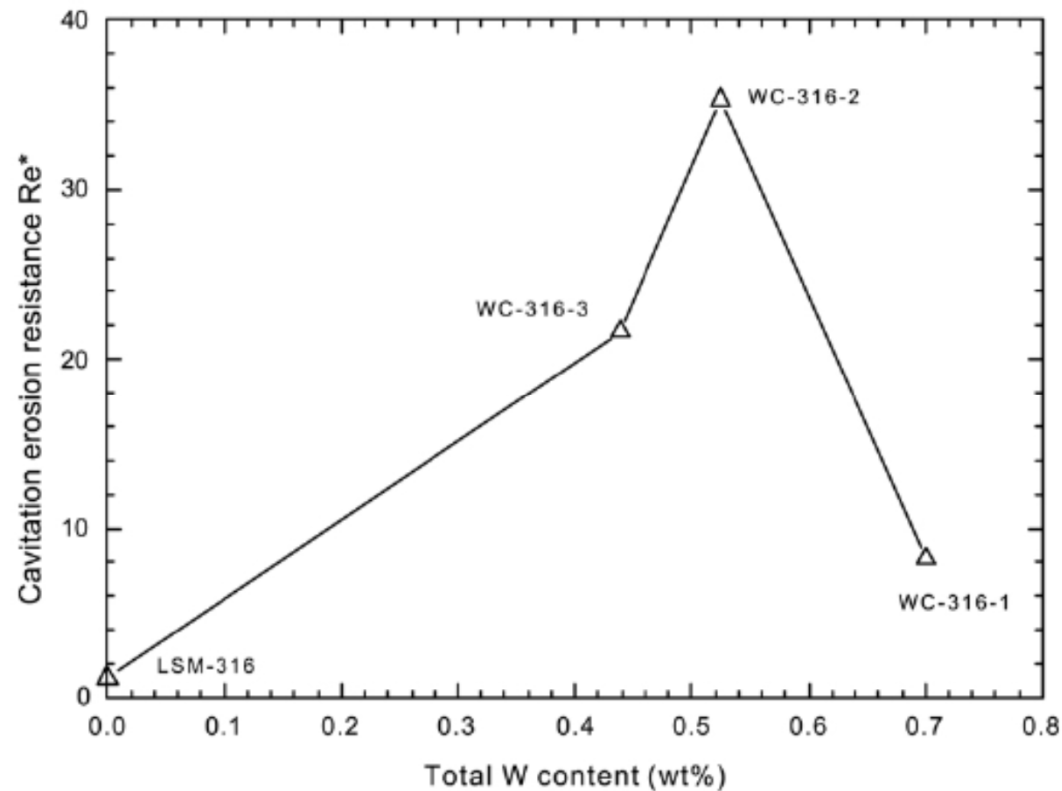

- Optimised cavitation erosion resistance is obtained after complete dissolution of WC particles and reprecipitation of an extremely fine structure

[Lo et al, 2003]

Results and discussion (3)

SS 316L + WC

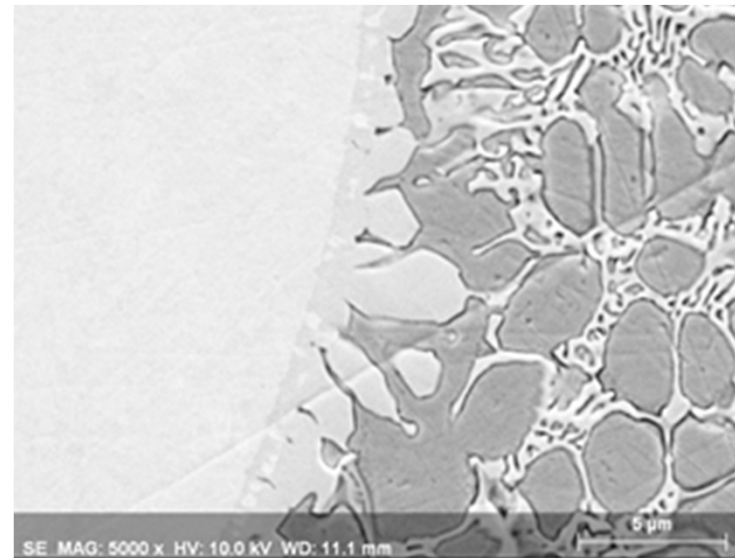
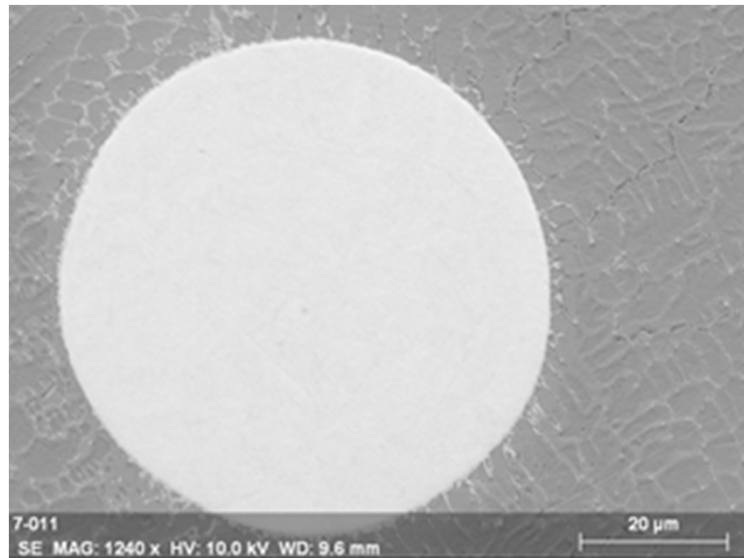

- Partial dissolution of WC
 - **Secondary precipitation** of WC, W_2C and other carbides ($M_{23}C_6$, M_7C_3 or M_6C) in a fine lamellar structure
 - Interdendritic spacing: 2-4 μm
- Microstructural refinement**

Addition of particles for microstructural refinement

NiCoCrAlY + nano CeO₂

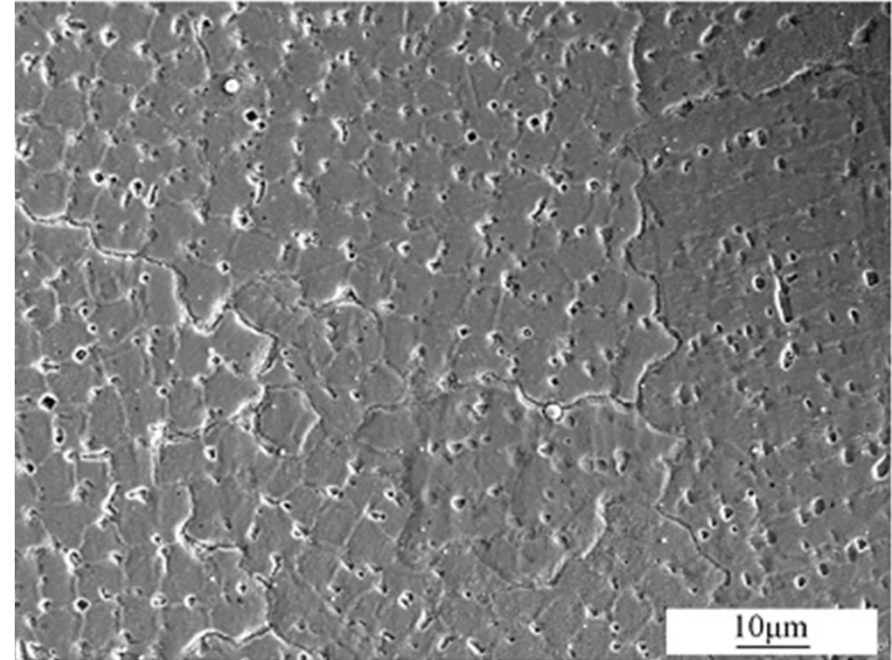
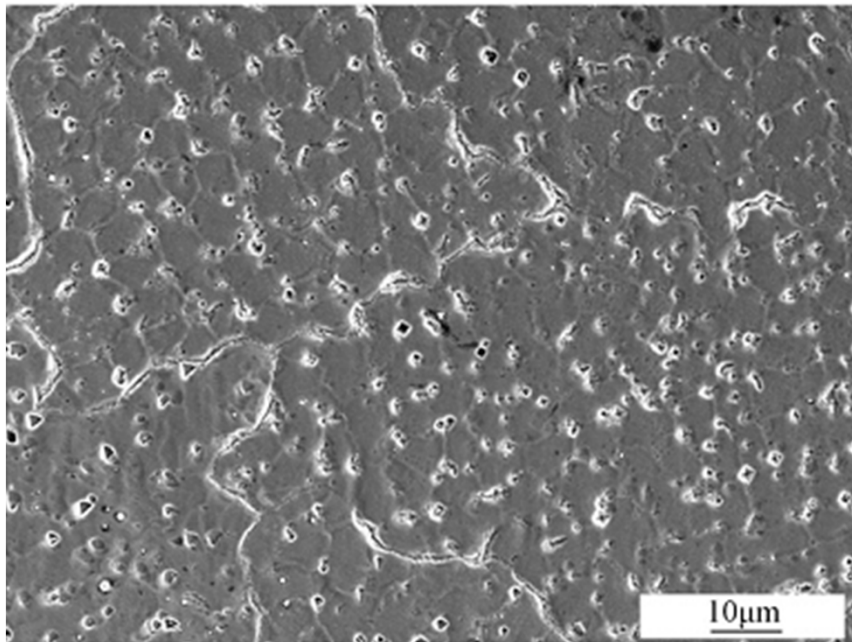

⇒ Microstructural refinement

[Wang et al., 2010]

Results and discussion (4)

SS 316L + WC

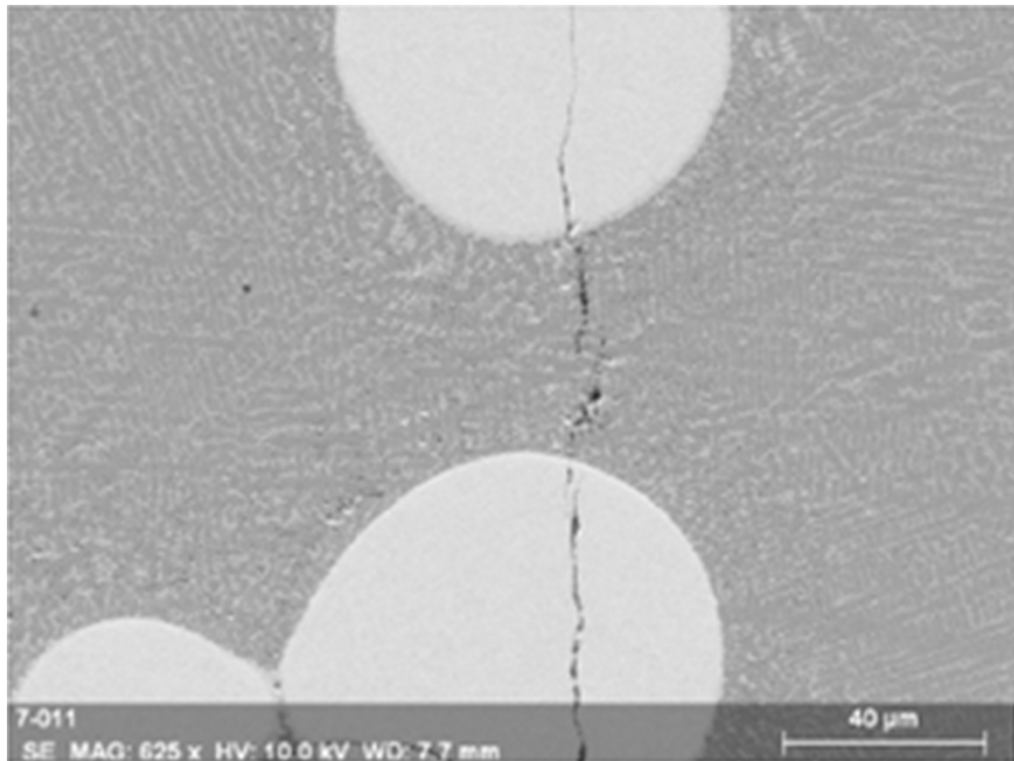

- **Cracks** occur at high WC content (>36%)
- Sometimes linking two or more adjacent particles
- Due to thermal mismatches between WC and matrix

[Mertens et al., 2017]

Results and discussion (5)

SS 316L + WC

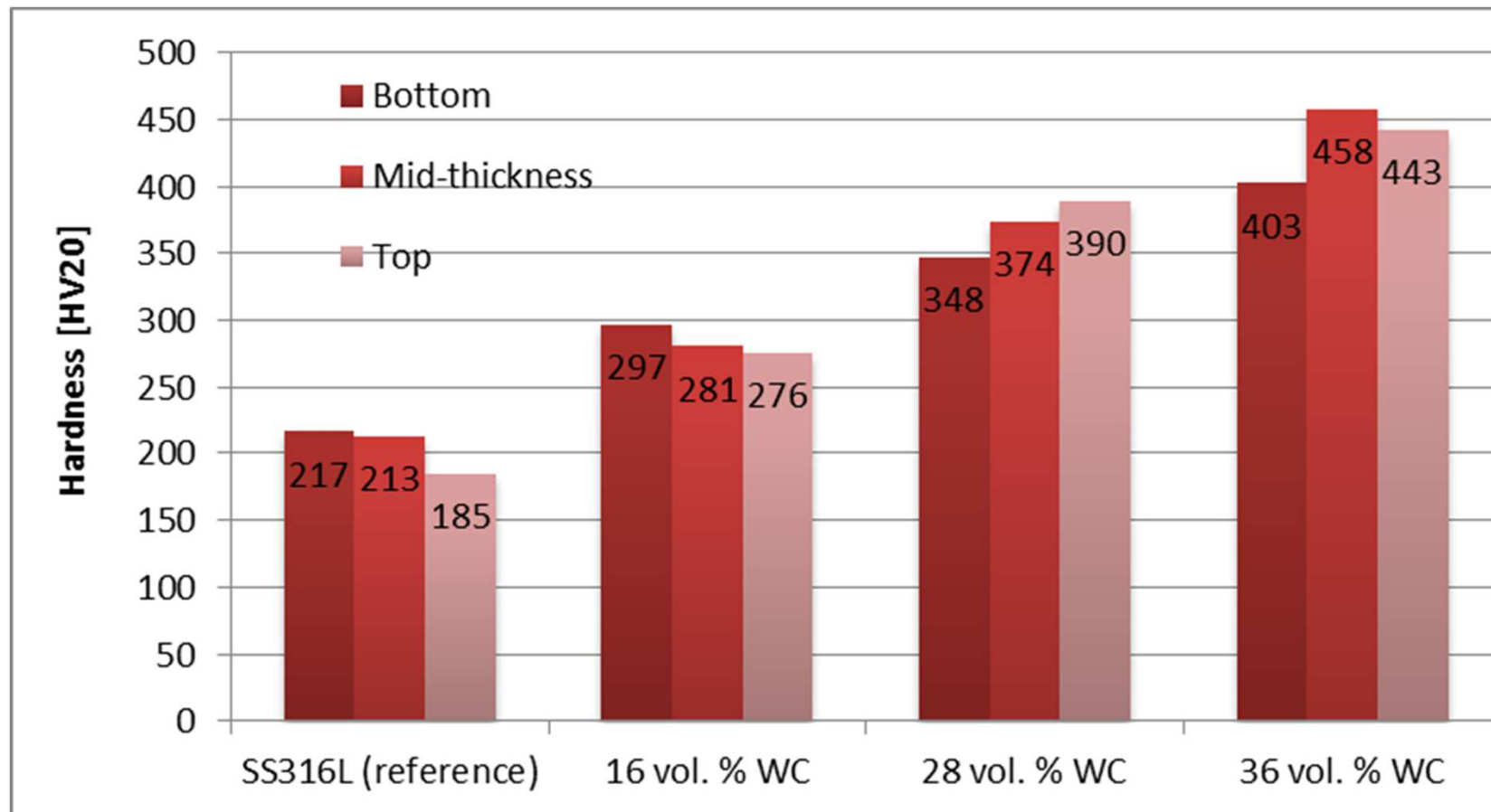

Hardness presents a complex variation pattern as a function of both position and WC content

Results and discussion (6)

SS 316L + WC

- Hardness presents a **complex variation** pattern as a function of both position and WC content
- Combined effect of **particles, precipitates and solid solution strengthening**
- Higher laser absorptivity of WC compared to SS 316L
⇒ **WC content influences the local thermal history**

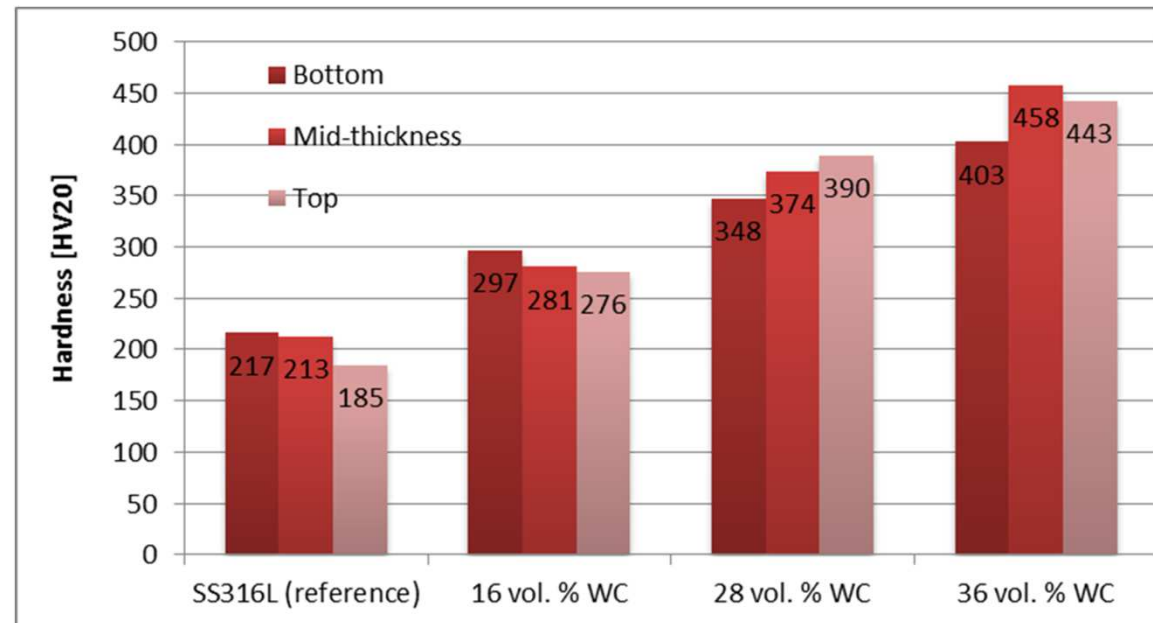

[Mertens et al., 2017]

Heat balance during the processing of FGMs

Graded Ti6Al4V + TiC

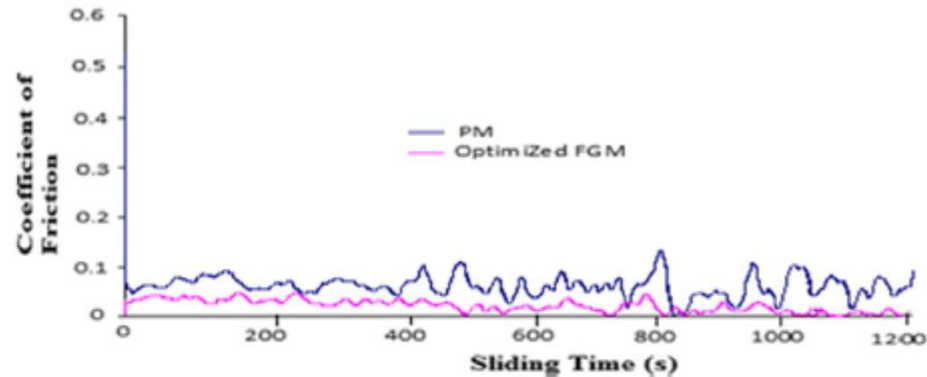

FGMs Ti6Al4V + TiC is have a better wear behaviour when the processing parameters are varied as a function of the TiC volume fraction

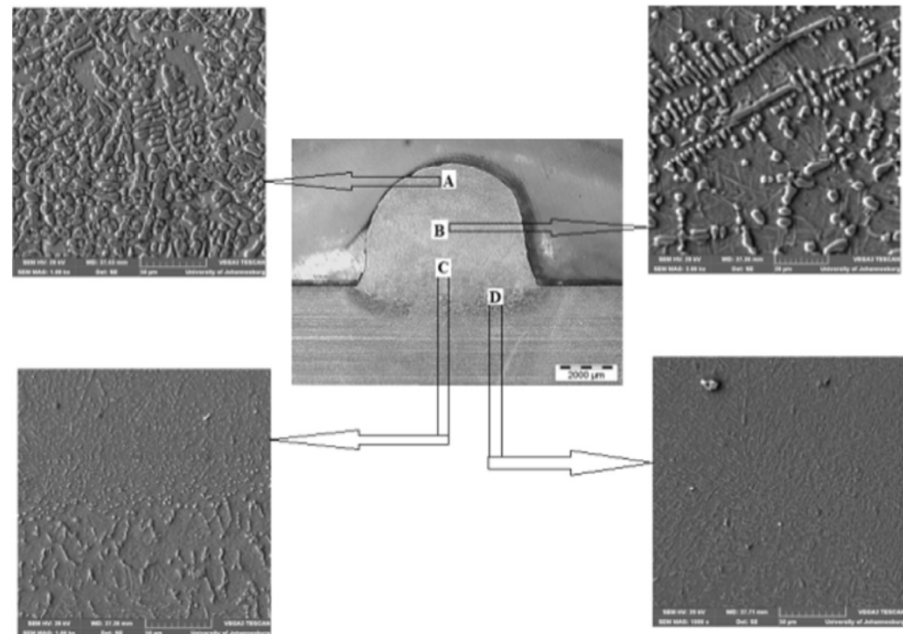

[Mahamood & Akinlabi, 2015]

Concluding remarks (1)

- Sound composite coatings were made by laser cladding Stainless Steel 316L + SiC or WC particles
- Extensive dissolution of SiC vs partial dissolution of WC
- Hardness of both types of composite coatings was significantly enhanced in comparison with reference SS 316L coating, due to strengthening by the surviving particles, but also by secondary precipitates and solid solution
- High WC contents led to cracking of the WC particles due to thermal stresses arising between the particles and the matrix

Concluding remarks (2)

- Laser Cladding is a powerful technique for the production of Metal Matrix Composites and Functionally Graded Materials (FGMs)
- Thermal history is complex and may vary locally as a function of position inside a part.
 - ⇒ Microstructure may vary locally
 - ⇒ Mechanical properties may vary locally
- The volume fraction of reinforcement particles is an important parameter that controls the microstructure directly (chemistry) and indirectly (i.e. by influencing the thermal history)

References

- A.Ahmed &H.J.Rack, Mater. Sci. Eng. A (1998), 243:206
S.Bhattacharya et al., Mater. Sci. Eng. A (2011) 528:2309
J.Dutta Majumdar et al., JMPT (2009) 209:2237
M.L.Griffith et al., Mater. Design. (1999) 20:107
S.Kumar & J.P.Kruth, Mater. Design (2010) 31:850
K.H. Lo et al., Surface and Coatings Technology (2003) 165:258
R.M.Mahamood & E.T.Akinlabi, Mater. Design (2015) 84:402
S.Mahathanabodee et al., Wear (2014) 316:37
A.Mertens et al., Proc. ECSSMET (2012), ESA SP-691
A.Mertens et al., MSF (2014), 783-786:898
A.Mertens et al., Powder Met. (2014), 57:184
A.Mertens et al., Proc. Conf Ti2015, San Diego (CA), 16-20 Aug. 2015
A.Mertens & J. Lecomte-Beckers, in "New Trends in 3D Printing", ed. I.V.Sishkovsky, Intech (2016), 187
A.Mertens et al., MSF (2017) 879:1288
T.Niendorf et al., Metall. Mater. Trans. B (2013), 44:794
H.Paydas, A.Mertens et al., Mater. Design (2015) 85: 497
Z.Quan et al., Materials Today (2015) 18:503
S.Reginster et al., MSF (2013), 765:413
L.Thijs et al., Acta Mater. (2010), 58:3303
H.Wang et al., Corrosion Science (2010) 52:3561
Q.Wei et al., JMPT (2015) 222:444
I.Yadroitsev et al., J. Mater. Process. Technol. (2010), 210:1624

All publications from ULg can be obtained from: <http://orbi.ulg.ac.be/>

Acknowledgements

Thank you to

The European Fund for Regional Development and the Walloon Region (Belgium), Projects FEDER TipTopLam and lawatha

The Interuniversity Attraction Poles Programme initiated by the Belgian Science Policy Office, contract IAP7/21 "INTEMATE"

for their financial support.

Thank you to the Additive Manufacturing Team (Sirris) and to my colleagues from ULg (Mrs S.Salieri, N.Hashemi, S.Reginster and J.Lecomte-Beckers, Mr O.Dedry, T.L'Hoest, H.Paydas and J.T.Tchuindjang)

Thank you for your attention!